

City of Strongsville

16099 Foltz Parkway
Strongsville, Ohio 44149-5598
Phone: 440-580-3110
Council Office Fax: 440-572-1648
www.strongsville.org

December 1, 2016

City Council

Michael J. Daymut
Ward 1

Matthew A. Schonhut
Ward 2

James E. Carbone
Ward 3

Gordon C. Short
Ward 4

Joseph C. DeMio
At-Large

Kenneth M. Dooner
President Pro Tem
At-Large

Duke Southworth
President of Council
At-Large

Aimee Pientka, CMC
Clerk of Council
aimee.pientka@strongsville.org

Tiffany Mekeel, CMC
Assistant Clerk of Council
tiffany.mekeel@strongsville.org

MEETING NOTICE

City Council has scheduled the following meetings for **Monday, December 5, 2016**, to be held in the Caucus Room and the Council Chamber at the **Mike Kalinich Sr. City Council Chamber, 18688 Royalton Road:**

Caucus will begin at 7:30 p.m. All committees listed will meet immediately following the previous committee:

7:30 P.M. **Planning, Zoning and Engineering Committee** will meet to discuss Ordinance Nos. 2016-225 and 2016-226.

Recreation and Community Services will meet to discuss Ordinance No. 2016-227 and Resolution No. 2016-228.

Finance Committee will meet to discuss Ordinance No. 2016-230 and Resolution No. 2016-229.

Economic Development will meet to discuss items pertinent to the committee.

Committee of the Whole will consider a motion to adjourn into **Executive Session** to discuss personnel matters.

8:00 P.M. **Regular Council Meeting**

Any other matters that may properly come before this Council may also be discussed.

BY ORDER OF THE COUNCIL:

Aimee Pientka, MMC
Clerk of Council

**STRONGSVILLE CITY COUNCIL REGULAR MEETING
MONDAY, DECEMBER 5, 2016 AT 8:00 P.M.**

Mike Kalinich Sr. City Council Chamber
18688 Royalton Road, Strongsville, Ohio

AGENDA

1. CALL TO ORDER:
2. PLEDGE OF ALLEGIANCE:
3. CERTIFICATION OF POSTING:
4. ROLL CALL:
5. COMMENTS ON MINUTES:
 - *Council Meeting – November 21, 2016*
6. APPOINTMENTS, CONFIRMATIONS, AWARDS AND RECOGNITION:
7. REPORTS OF COUNCIL COMMITTEE:
 - SCHOOL BOARD – Mr. Carbone:
 - SOUTHWEST GENERAL HEALTH SYSTEM – Mr. Southworth:
 - BUILDING AND UTILITIES – Mr. Schonhut:
 - COMMUNICATIONS AND TECHNOLOGY – Mr. Schonhut:
 - ECONOMIC DEVELOPMENT – Mr. Daymut:
 - FINANCE – Mr. Dooner:
 - PLANNING, ZONING AND ENGINEERING – Mr. Daymut:
 - PUBLIC SAFETY AND HEALTH – Mr. DeMio:
 - PUBLIC SERVICE AND CONSERVATION – Mr. Carbone:
 - *Motion to note and approve the owner's designation of wishes for interments in Strongsville Municipal Cemetery, Section F, Lot# 105, Graves D and F.*
 - RECREATION AND COMMUNITY SERVICES – Mr. Short:
 - COMMITTEE-OF-THE-WHOLE – Mr. Southworth:

8. REPORTS AND COMMUNICATIONS FROM THE MAYOR, DIRECTORS OF DEPARTMENTS AND OTHER OFFICERS:

- MAYOR PERCIAK:
- FINANCE DEPARTMENT:
- LAW DEPARTMENT:

9. AUDIENCE PARTICIPATION:

10. ORDINANCES AND RESOLUTIONS:

- Ordinance No. 2016-225 by Mr. Daymut. AN ORDINANCE AMENDING THE ZONING MAP OF THE CITY OF STRONGSVILLE ADOPTED BY SECTION 1250.03 OF TITLE SIX, PART TWELVE OF THE CODIFIED ORDINANCES OF STRONGSVILLE TO CHANGE THE ZONING CLASSIFICATION OF CERTAIN PROPERTY LOCATED AT 21487 ROYALTON ROAD (PORTIONS OF PPNs 393-03-007 AND 393-03-008) IN THE CITY OF STRONGSVILLE, FROM GI (GENERAL INDUSTRIAL) CLASSIFICATION TO GB (GENERAL BUSINESS) CLASSIFICATION, AND DECLARING AN EMERGENCY.
- Ordinance No. 2016-226 by Mayor Perciak and Mr. Daymut. AN ORDINANCE APPROVING AND AUTHORIZING THE FILING OF AN APPLICATION FOR TRANSPORTATION FOR LIVABLE COMMUNITIES INITIATIVE IMPLEMENTATION GRANT FUNDING ASSISTANCE WITH THE NORTHEAST OHIO AREAWIDE COORDINATING AGENCY, IN CONNECTION WITH THE CITY OF STRONGSVILLE TOWN CENTER DISTRICT IMPROVEMENTS PROJECT, AND DECLARING AN EMERGENCY.
- Ordinance No. 2016-227 by Mayor Perciak and Mr. Short. AN ORDINANCE APPROVING NEW RATES FOR THE RENTAL OF FACILITIES AT THE WALTER F. EHRNFELT RECREATION AND SENIOR CENTER, AND CITY OF STRONGSVILLE OLD TOWN HALL, AND DECLARING AN EMERGENCY.
- Resolution No. 2016-228 by Mayor Perciak and Mr. Short. A RESOLUTION AUTHORIZING THE MAYOR TO ADVERTISE FOR BIDS FOR THE RENOVATION OF FOUR LOCKER ROOMS AT THE CITY OF STRONGSVILLE WALTER F. EHRNFELT RECREATION & SENIOR CENTER, AND DECLARING AN EMERGENCY.
- Resolution No. 2016-229 by Mayor Perciak and Mr. Dooner. A RESOLUTION ESTABLISHING A FUND TO BE KNOWN AS THE HEALTH INSURANCE RESERVE FUND, NO. 661.
- Ordinance No. 2016-230 by Mayor Perciak and All Members of Council. AN ORDINANCE AUTHORIZING THE MAYOR TO ENTER INTO A CONTRACT FOR A COMPREHENSIVE HEALTH BENEFITS PLAN FOR CITY EMPLOYEES FOR THE YEAR 2017, WITHOUT FURTHER PUBLIC BIDDING, AND DECLARING AN EMERGENCY.

11. COMMUNICATIONS, PETITIONS AND CLAIMS:

- Application for Permit: STOCK D5 D6: To: A1 Samurai Inc. DBA: Samurai Sushi & Steakhouse, 16670 Royalton Road Strongsville, Ohio 44136 (Responses must be postmarked no later than 12/12/2016).

12. MISCELLANEOUS BUSINESS:

13. ADJOURNMENT:

CITY OF STRONGSVILLE, OHIO

ORDINANCE NO. 2016 – 225

By: Mr. Daymut

AN ORDINANCE AMENDING THE ZONING MAP OF THE CITY OF STRONGSVILLE ADOPTED BY SECTION 1250.03 OF TITLE SIX, PART TWELVE OF THE CODIFIED ORDINANCES OF STRONGSVILLE TO CHANGE THE ZONING CLASSIFICATION OF CERTAIN PROPERTY LOCATED AT 21487 ROYALTON ROAD (PORTIONS OF PPNs 393-03-007 AND 393-03-008) IN THE CITY OF STRONGSVILLE, FROM GI (GENERAL INDUSTRIAL) CLASSIFICATION TO GB (GENERAL BUSINESS) CLASSIFICATION, AND DECLARING AN EMERGENCY.

BE IT ORDAINED BY THE COUNCIL OF THE CITY OF STRONGSVILLE, COUNTY OF CUYAHOGA, AND STATE OF OHIO:

Section 1. That the Zoning Map of the City of Strongsville, adopted by Section 1250.03 of Title Six, Part Twelve of the Codified Ordinances of Strongsville, be amended to change the zoning classification of certain property located at 21487 Royalton Road (portions of PPNs 393-03-007 and 393-03-008), from GI (General Industrial) classification to GB (General Business) classification, which property is more fully described and depicted in Exhibits "A" and "B", attached hereto and incorporated herein as if fully rewritten.

Section 2. That the Clerk of Council is hereby authorized to cause the necessary change on the Zoning Map to be made in order to reflect the zoning change in classification as provided in this Ordinance.

Section 3. That it is found and determined that all formal actions of this Council concerning and relating to the adoption of this Ordinance were adopted in an open meeting of this Council; and that all deliberations of this Council, and any of its committees, that resulted in such formal action were in meetings open to the public in compliance with all legal requirements.

Section 4. That this Ordinance is hereby declared to be an emergency measure necessary for the immediate preservation of the public peace, property, health, safety and welfare of the City, and for the further reason that it is immediately necessary to rezone such property in order to provide for the orderly development of lots and lands within the City, to afford the applicant an opportunity to submit plans and commence construction as weather permits, to enhance economic development within the City, and to conserve public funds. Therefore, provided this Ordinance receives the affirmative vote of two-thirds of all members elected to Council, it shall take effect and be in force immediately upon its passage and approval by the Mayor; otherwise from and after the earliest period allowed by law.

CITY OF STRONGSVILLE, OHIO
ORDINANCE NO. 2016 – 225
Page 2

First Reading: _____

Referred to Planning Commission

Second Reading: _____

Third Reading: _____

Approved: _____

Public Hearing: _____

President of Council

Approved: _____
Mayor

Date Passed: _____

Date Approved: _____

	<u>Yea</u>	<u>Nay</u>
Carbone	_____	_____
Daymut	_____	_____
DeMio	_____	_____
Dooner	_____	_____
Schonhut	_____	_____
Short	_____	_____
Southworth	_____	_____

Attest: _____
Clerk of Council

ORD. No. 2016-225 Amended: _____
1st Rdg. _____ Ref: _____
2nd Rdg. _____ Ref: _____
3rd Rdg. _____ Ref: _____

Pub Hrg. _____ Ref: _____
Adopted: _____ Defeated: _____

PETITION FOR ZONING CHANGE

Ordinance Number: 2016-225

To the Council of the City of Strongsville, County of Cuyahoga, State of Ohio:

I/We, the undersigned owner(s) of the property set above our names on the Property Description Form attached to this document, hereby petition your Honorable Body that said property be changed from a class GI use to a class GB use.

Such change is necessary for the preservation and enjoyment of a substantial property right because: It will fill a commercial need currently not being met in the community.
It will also begin the clean up of a property that community leaders feel is needed. Dividing this parcel into multiple uses is logical due to the properties shape

Such change will not be materially detrimental to the public welfare nor to the property of other persons located in the vicinity because: This parcel will combine multiple curb cuts down to a single access point. In the future, the zoning to the east is industrial and to the west is railroad tracks so no negative impact on either property

Please list other supporting documents (if any) which accompany this petition:

- A tractor Supply Site Plan
- Boundary Survey of entire 13acres
-

THE PROPOSED USE OF THE PROPERTY IS: A Tractor Supply Company
Retail store.

Name, address and **telephone number** of applicant or applicant's agent:

Name: Keith Carter
Address: 1076 Summitt Drive Middletown, OH 45042
Telephone Number: 513-292-5837

Frank Jarama / J.P. Larson Members
Signature of Owner(s) JARON & LARSON, LLC

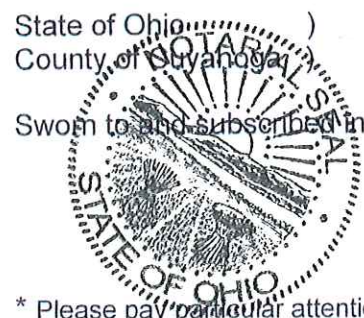

Sworn to and subscribed in my presence this 21st day of November, 2016.

Pamela J. O'Toole
Notary Public PAMELA J. O'TOOLE

My commission expires: _____
NOTARY PUBLIC • STATE OF OHIO
Recorded in Cuyahoga County
My commission expires Apr. 29, 2021

* Please pay particular attention to the details in item number 4 on page one. The certified list of property owners must be prepared by a title insurance company. Please provide a cover letter from the title insurance company verifying that said list was prepared by them.

PROPERTY DESCRIPTION FORM

Ordinance Number: 2016-225

The following described property is that property for which a change is being requested in the attached Petition for Zoning Change and which is hereby incorporated into and made part of said petition:

Address of Property: 21487 Royalton Road Strongsville, OH 44149

Permanent Parcel No.: 393-03-007 + 393-03-008 + 393-05-008

The property is bounded by the following streets: (indicate direction; i.e., north, south, etc.) The southern property boundary is Royalton Road

Number and type of buildings which now occupy property (if any): There is an existing residential home with a garage and an existing commercial landscape office w/out build.

Acreage: entire site is 13 acres. We are rezoning 3.753

Said property (has) (had) the following deed restrictions affecting the use thereof (attach copy): None

Said deed restrictions (will) (have) expire(d) on: N/A

Said property is presently under lease or otherwise encumbered as follows: Residential home is month to month and Landscape company is on a short term lease

Owner(s)	Percent of Ownership:
1. <u>JASON FEISCONE</u>	<u>50%</u> %
2. <u>FRANK JARAM</u>	<u>50%</u> %
3. _____	_____ %

Frank Jaram / J. Feiscone Members
Signature of Owner(s) JARAME LAND, LLC

State of Ohio)
County of Cuyahoga)

Sworn to and subscribed to in my presence this 21st day of November, 2016.



Pamela J. O'Toole
Notary Public

My commission expires PAMELA J. O'TOOLE
NOTARY PUBLIC - STATE OF OHIO
Recorded in Cuyahoga County
My commission expires Apr. 29, 2021

* Please pay particular attention to the details in item number 4 on page one. The certified list of property owners must be prepared by a title insurance company. Please provide a cover letter from the title insurance company verifying that said list was prepared by them.

LEGAL DESCRIPTION

BEING A TRACT OF LAND OWNED BY JARONE LAND COMPANY LLC. AS DESCRIBED IN AFN 201007300211 OF THE CUYAHOGA COUNTY DEED RECORDS, SITUATE IN THE CITY OF STRONGSVILLE, COUNTY OF CUYAHOGA, STATE OF OHIO, AND KNOWN AS BEING PART OF ORIGINAL STRONGSVILLE TOWNSHIP LOT NUMBER 85, OHIO AND BEING MORE PARTICULARLY DESCRIBED AS FOLLOWS:

Commencing for reference at a monument box found with a 5/8" iron pinned capped "Skonieczny, S-6356" at the northwest corner of Out Lot 85 as Part of the Original Strongville Township Lots;

thence, South 88°-35'-59" East, 1103.99 feet, along the centerline of State Route 82, also known as Royalton Road to the northeast corner of a tract of land owned by Anna L. St. Peter as described in Volume 15676, Page 451;

thence, South 00°-33'-24" West, 40.00 feet, along the east line of said St. Peter tract to an iron pin with cap found on the south right-of-way line of State Route 82;

thence, South 88°-35'-58" East, 200.00 feet, along the south right-of-way line of State Route 82 to a point, and being the principal place of beginning of the tract herein described;

thence, South 88°-35'-58" East, 100.00 feet, to a point;

thence, South 00°-33'-24" West, 545.00 feet, to a point;

thence, North 88°-35'-58" West, 100.00 feet, to a point;

thence, North 00°-33'-24" East, 545.00 feet, to the principal place of beginning.

Containing 1.251 acres more or less and all being subject to any legal highway and easements of record.

The bearings are assumed and used to denote angles only.

The above description was prepared by Allen J. Bertke, Ohio Professional Surveyor Number 8629.

This legal description is to be used for Zoning approval only and not for property transfer.

This survey was prepared based on a survey performed by Bramhall Engineering and Surveying Co., Inc. in 2011. No field work was performed in preparing this exhibit and legal description.

EXHIBIT A

**SITUATED IN THE CITY OF STRONGSVILLE, COUNTY OF CUYAHOGA, STATE OF OHIO
AND BEING PART OF ORIGINAL STRONGSVILLE TOWNSHIP LOT NUMBER 85**

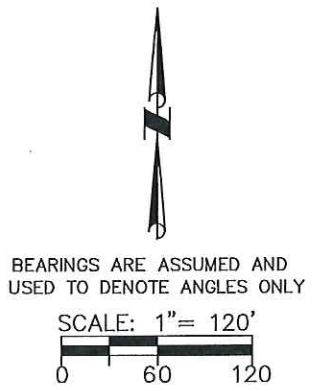
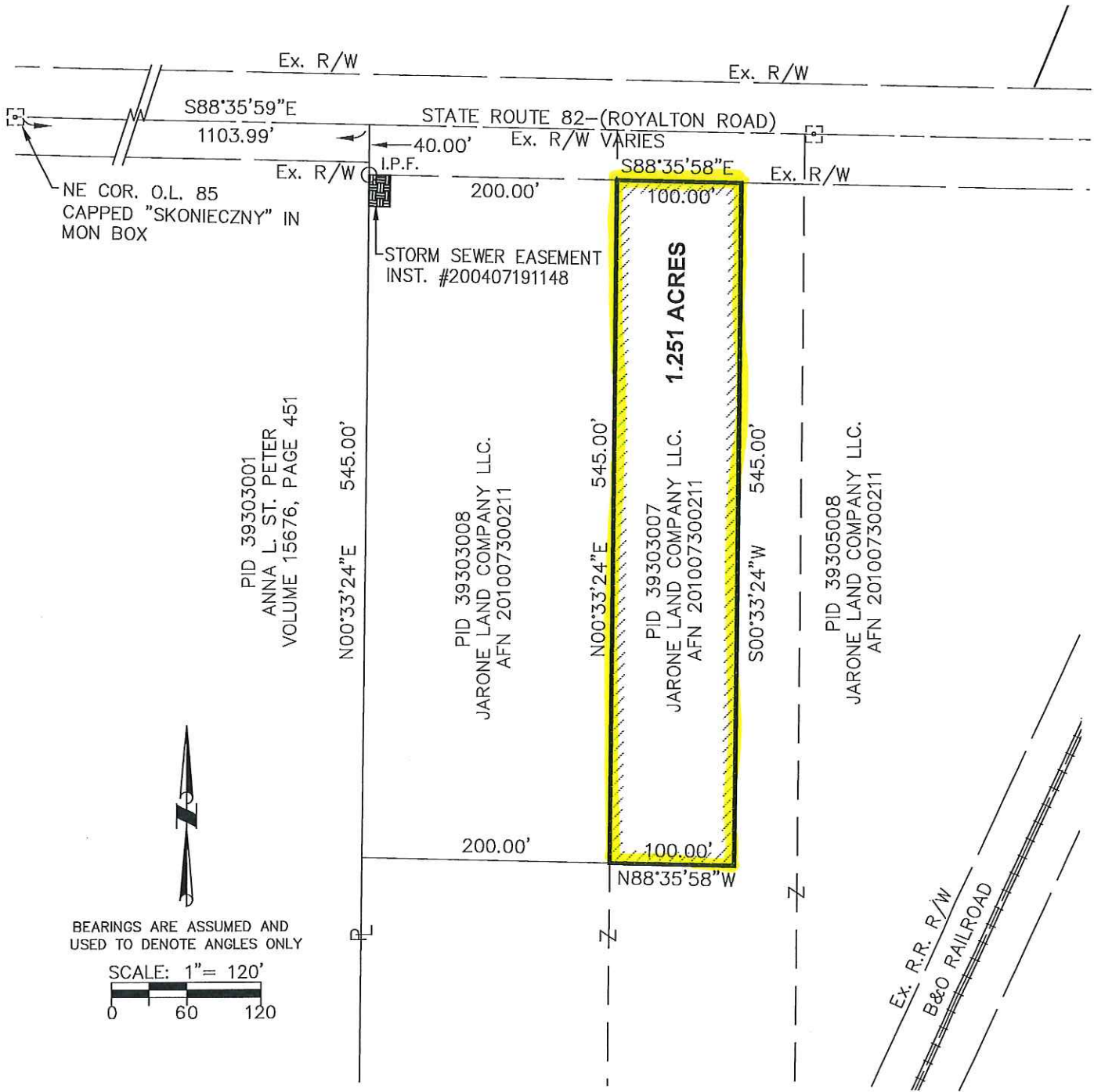

SIDNEY, OHIO 937.497.0200
LOVELAND, OHIO 513.239.8554
PORTLAND, INDIANA 260.766.2500
www.CHOICEONEENGINEERING.com

LEGEND

- I.P.F. IRON PIN FOUND
- ☒ MONUMENT BOX W/IP FOUND

LEGAL DESCRIPTION

BEING A TRACT OF LAND OWNED BY JARONE LAND COMPANY LLC. AS DESCRIBED IN AFN 201007300211 OF THE CUYAHOGA COUNTY DEED RECORDS, SITUATE IN THE CITY OF STRONGSVILLE, COUNTY OF CUYAHOGA, STATE OF OHIO, AND KNOWN AS BEING PART OF ORIGINAL STRONGSVILLE TOWNSHIP LOT NUMBER 85, OHIO AND BEING MORE PARTICULARLY DESCRIBED AS FOLLOWS:

Commencing for reference at a monument box found with a 5/8" iron pinned capped "Skonieczny, S-6356" at the northwest corner of Out Lot 85 as Part of the Original Strongville Township Lots;

thence, South 88°-35'-59" East, 1103.99 feet, along the centerline of State Route 82, also known as Royalton Road to the northeast corner of a tract of land owned by Anna L. St. Peter as described in Volume 15676, Page 451;

thence, South 00°-33'-24" West, 40.00 feet, along the east line of said St. Peter tract to an iron pin with cap found on the south right-of-way line of State Route 82, and being the principal place of beginning of the tract herein described;

thence, South 88°-35'-58" East, 200.00 feet, along the south right-of-way line of State Route 82 to a point;

thence, South 00°-33'-24" West, 545.00 feet, to a point;

thence, North 88°-35'-58" West, 200.00 feet, to a point on the east line of said St. Peter tract;

thence, North 00°-33'-24" East, 545.00 feet, along the east of said St. Peter tract to the principal place of beginning.

Containing 2.502 acres more or less and all being subject to any legal highway and easements of record.

The bearings are assumed and used to denote angles only.

The above description was prepared by Allen J. Bertke, Ohio Professional Surveyor Number 8629.

This legal description is to be used for Zoning approval only and not for property transfer.

This survey was prepared based on a survey performed by Bramhall Engineering and Surveying Co., Inc. in 2011. No field work was performed in preparing this exhibit and legal description.

EXHIBIT B

**SITUATED IN THE CITY OF STRONGSVILLE, COUNTY OF CUYAHOGA, STATE OF OHIO
AND BEING PART OF ORIGINAL STRONGSVILLE TOWNSHIP LOT NUMBER 85**

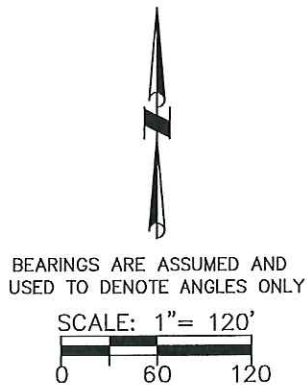
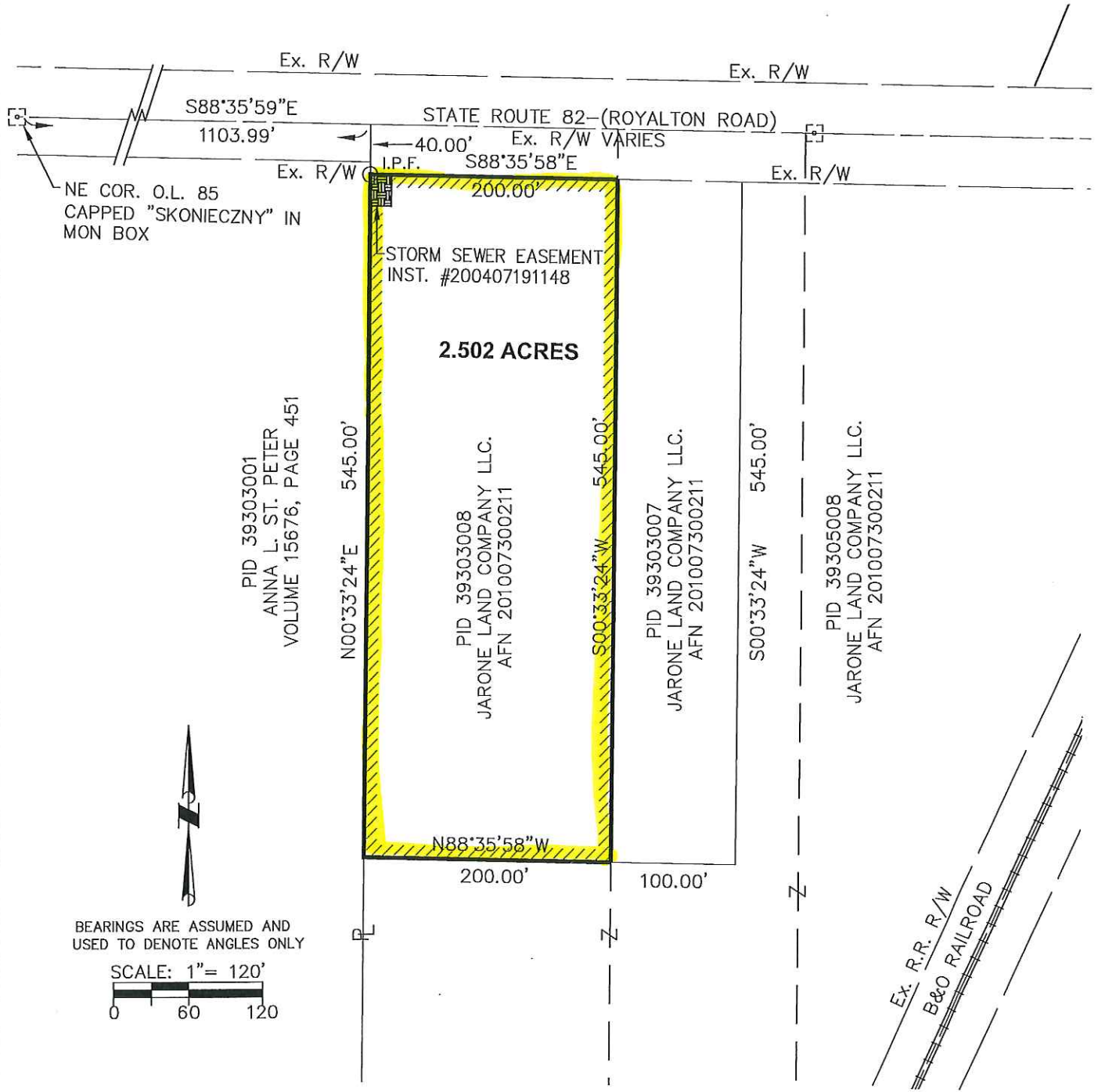

SIDNEY, OHIO 937.497.0200
LOVELAND, OHIO 513.239.8554
PORTLAND, INDIANA 260.766.2500
www.CHOICEONEENGINEERING.com

LEGEND

- I.P.F. IRON PIN FOUND
- ⊠ MONUMENT BOX W/IP FOUND

CITY OF STRONGSVILLE
OFFICE OF THE COUNCIL

MEMORANDUM

TO: Ken Mikula, City Engineer

FROM: Aimee Pientka, Clerk of Council

DATE: November 21, 2016

SUBJECT: Rezoning Application
Jason Friscone and Frank Jaram; Owners
PPNs: 393-03-007 (portion) and 393-03-008 (portion)
Address: 21487 Royalton Road
From General Industrial (GI) to General Business (GB)

Please check the legal description on the attached application for rezoning and, if correct, please forward to the Law Director so he may prepare legislation for Council to consider.

Thank you.

AKP
Attachments

cc: Thomas P. Perciak, Mayor
Neal Jamison, Law Director
Daniel J. Kolick, Assistant Law Director
George Smerigan, City Planner
Brent Painter, Economic Development Director
All Members of Council
Carol Opera, Planning Commission Secretary

CITY OF STRONGSVILLE, OHIO

ORDINANCE NO. 2016 – 226

By: Mayor Perciak and Mr. Daymut

AN ORDINANCE APPROVING AND AUTHORIZING THE FILING OF AN APPLICATION FOR TRANSPORTATION FOR LIVABLE COMMUNITIES INITIATIVE IMPLEMENTATION GRANT FUNDING ASSISTANCE WITH THE NORTHEAST OHIO AREAWIDE COORDINATING AGENCY, IN CONNECTION WITH THE CITY OF STRONGSVILLE TOWN CENTER DISTRICT IMPROVEMENTS PROJECT, AND DECLARING AN EMERGENCY.

WHEREAS, by and through Ordinance No. 2013-167, Council authorized the Mayor to file an application with the Northeast Ohio Areawide Coordinating Agency (NOACA) in order to undertake a planning study and report to assess alternative transportation means and land re-development within the City of Strongsville's Town Center area; and

WHEREAS, the City has been following through on the improvements recommended within the Strongsville Town Center study, which was completed by NOACA in December, 2015; and

WHEREAS, the Town Center Improvements Project seeks to improve pedestrian and bicycle safety and mobility throughout the Town Center by constructing median refuge islands, stamped concrete crosswalks and countdown pedestrian signals, as well as establishing crosswalks, bike racks and wayfinding signage within the Town Center area; and

WHEREAS, therefore, in order to avail itself of funding and meet the application filing deadline for financial assistance, the City intends to make application to NOACA through the 2017 Transportation for Livable Communities Initiative Implementation Grant for project funding assistance in the amount of \$188,000.00, with a City of Strongsville Local Match cost of \$136,000.00, for a total project cost of \$324,000.00.

NOW, THEREFORE, BE IT ORDAINED BY THE COUNCIL OF THE CITY OF STRONGSVILLE, COUNTY OF CUYAHOGA AND STATE OF OHIO:

Section 1. That this Council hereby approves and authorizes the Mayor's filing of an application with NOACA for 2017 Transportation for Livable Communities Initiative Implementation Grant funding assistance in connection with the City of Strongsville's Town Center District Improvements Project, a copy of which Application is on file with the City Engineer, and which, in all respects, is hereby approved; and further authorizes and directs the Mayor, the Director of Finance and City Engineer, and their authorized designees to provide, execute and deliver such other documents and information as may be required in furtherance thereof.

Section 2. That, if such grant is approved, the City's portion of its required share and any additional costs shall be appropriated and paid from the General Capital Improvement Fund, Tax Increment Financing (TIF) Funds and/or such other local, state or federal funds which may become available for such Project.

Section 3. That it is found and determined that all formal actions of this Council concerning and relating to the adoption of this Ordinance were adopted in an open meeting of this Council; and that all deliberations of this Council, and any of its committees, that resulted in such formal action were in meetings open to the public in compliance with all legal requirements.

Section 4. That this Ordinance is hereby declared to be an emergency measure immediately necessary for the preservation of the public peace, health, safety and welfare of the City, and for the further reason that it is immediately necessary to authorize and approve the filing of the application in order to meet the deadline and be eligible to receive the requested NOACA funding assistance to improve mobility throughout the Town Center area, promote economic re-development and land improvements within the City, and to conserve public funds. Therefore, provided this Ordinance receives the affirmative vote of two-thirds of all members elected to Council, it shall take effect and be in force immediately upon its passage and approval by the Mayor; otherwise from and after the earliest period allowed by law.

_____ Approved: _____
 President of Council Mayor

Date Passed: _____ Date Approved: _____

	<u>Yea</u>	<u>Nay</u>
Carbone	_____	_____
Daymut	_____	_____
DeMio	_____	_____
Dooner	_____	_____
Schonhut	_____	_____
Short	_____	_____
Southworth	_____	_____

Attest: _____
 Clerk of Council

ORD. No. 2016-226 Amended: _____
 1st Rdg. _____ Ref: _____
 2nd Rdg. _____ Ref: _____
 3rd Rdg. _____ Ref: _____

 Pub Hrg. _____ Ref: _____
 Adopted: _____ Defeated: _____

CITY OF STRONGSVILLE, OHIO

ORDINANCE NO. 2016 – 227

By: Mayor Perciak and Mr. Short

AN ORDINANCE APPROVING NEW RATES FOR THE RENTAL OF FACILITIES AT THE WALTER F. EHRSFELT RECREATION AND SENIOR CENTER, AND CITY OF STRONGSVILLE OLD TOWN HALL, AND DECLARING AN EMERGENCY.

WHEREAS, by and through Ordinance No. 1998-18, Council established fees to be charged persons or entities wishing to rent facilities at the Walter F. Ehrnfelt Recreation and Senior Center; and

WHEREAS, the City's Director of Recreation & Senior Services, recently has studied and reviewed the costs of operation of the Walter F. Ehrnfelt Recreation and Senior Center, as well as the City of Strongsville Old Town Hall, and has developed a revised recommended schedule of rental rates to be charged to the users thereof in order to defray a reasonable portion of such costs of operation and rental; and

WHEREAS, this Council has reviewed the recommendations of the Director of Recreation & Senior Services and is desirous of implementing said new facility rental rates.

NOW, THEREFORE, BE IT ORDAINED BY THE COUNCIL OF THE CITY OF STRONGSVILLE, COUNTY OF CUYAHOGA, AND STATE OF OHIO:

Section 1. That the rental rates established for rental of facilities at the Walter F. Ehrnfelt Recreation and Senior Center and City of Strongsville Old Town Hall will be as set forth in Exhibit A attached hereto and incorporated herein as if fully rewritten. The Director of Recreation and Senior Services be and is hereby authorized to maintain rules and regulations for the rental of the aforementioned facilities.

Section 2. That the rental fees collection shall be paid into the Multi-Purpose Complex Fund.

Section 3. That it is found and determined that all formal actions of this Council concerning and relating to the adoption of this Ordinance were adopted in an open meeting of this Council; and that all deliberations of this Council, and any of its committees, that resulted in such formal action were in meetings open to the public in compliance with all legal requirements.

CITY OF STRONGSVILLE, OHIO

ORDINANCE NO. 2016 – 227

Page 2

Section 4. That this Ordinance is hereby declared to be an emergency measure immediately necessary for the preservation of the public peace, health, safety and welfare of the City, and for the further reason that the aforesaid rental fees are necessary in order to pay for a reasonable portion of the costs of the operation of those City facilities, and to conserve funds. Therefore, provided this Ordinance receives the affirmative vote of two-thirds of all members elected to Council, it shall take effect and be in force immediately upon its passage and approval by the Mayor; otherwise from and after the earliest period allowed by law.

President of Council

Approved: _____
Mayor

Date Passed: _____

Date Approved: _____

	<u>Yea</u>	<u>Nay</u>
Carbone	_____	_____
Daymut	_____	_____
DeMio	_____	_____
Dooner	_____	_____
Schonhut	_____	_____
Short	_____	_____
Southworth	_____	_____

Attest: _____
Clerk of Council

ORD. No. 2016-227 Amended: _____

1st Rdg. _____ Ref: _____

2nd Rdg. _____ Ref: _____

3rd Rdg. _____ Ref: _____

Pub Hrg. _____ Ref: _____

Adopted: _____ Defeated: _____

**EHRNFELT RECREATION & SENIOR CENTER
FACILITY RENTAL RATES
PER HOUR**

ROOM	Non		Business (8 hours or more)		NON- PROFIT
	Member	Member	Member	Member	
Whole Event Center	\$125	\$150			\$75
Half Event Center	\$75	\$100			\$55
Event Center (12 hr. block) - Whole	\$1,100	\$1,400			
Event Center (12 hr. block) - Half	\$600	\$900			
Kitchen	\$150	\$175			
Kitchen (12-hr. block)	\$1,500	\$1,750			
Concession Stand (Flat Rate)	\$60	\$85			
Concession Area	\$45	\$65			
Avenue: Entire space	\$75	\$100			
Avenue: Table Rental (Flat Rate)	\$100	\$125			\$75
Conference Room	\$45	\$65	\$35	\$55	\$45
Meeting Room	\$45	\$65	\$35	\$55	\$45
Senior Activity Studio	\$45	\$65	\$35	\$55	\$45
Senior Art Studio	\$45	\$65	\$35	\$55	\$45
Senior Meeting Room	\$45	\$65	\$35	\$55	\$45
Senior Craft Room	\$45	\$65	\$35	\$55	\$45
Senior Great Room	\$75	\$100	\$35	\$55	\$45
AFTER HOUR FEE for rooms above (in addition to hourly rental fee)**	\$120				
*Gym: Auxiliary	\$195	\$245			
*Gym: Main	\$220	\$270			
*Aquatic Center: Entire	\$530	\$680			
*Aquatic Center: Activity Pool	\$380	\$455			
*Aquatic Center: Competition Pool	\$355	\$430			
*Old Town Hall (each floor)	\$55	\$75	\$45	\$65	\$45
*Old Town Hall (both floors)	\$85	\$105	\$75	\$95	\$75
*Old Town Hall Kitchen (Flat Rate)	\$50	\$70			
*Old Town Hall - Entire (12 hr. block)	\$900	\$1,200			
Facility Use Charges (discounted admission rates with room rental)	\$3.00 (ages 7+)	\$2.00 (ages 4-6)	Free (ages 0-3)		

*AFTER HOUR FEE INCLUDED and only available to rent after business hours.

**AFTER HOUR FEE does not apply to 12 hour block of event center rental

Room Rental Fees are per hour with a two-hour minimum with the exception of the Concession Area which is available for a one-hour rental.

NON-PROFIT Classification: Any non-profit tax exempt corporations community/civic organizations, churches, fraternal bodies, private schools, hospitals, college/education units or government organizations/agencies must supply a 501 (c) (3) number or a tax exempt certificate to receive Non-Profit Classification rates.

EXHIBIT A

CITY OF STRONGSVILLE, OHIO

RESOLUTION NO. 2016 – 228

By: Mayor Perciak and Mr. Short

A RESOLUTION AUTHORIZING THE MAYOR TO ADVERTISE FOR BIDS FOR THE RENOVATION OF FOUR LOCKER ROOMS AT THE CITY OF STRONGSVILLE WALTER F. EHRNFELT RECREATION & SENIOR CENTER, AND DECLARING AN EMERGENCY.

BE IT RESOLVED BY THE COUNCIL OF THE CITY OF STRONGSVILLE, COUNTY OF CUYAHOGA, AND STATE OF OHIO:

Section 1. That the Mayor be and is hereby authorized to advertise for bids for the renovation of four (4) locker rooms at the Walter F. Ehrnfelt Recreation & Senior Center, all in accordance with specifications on file in the office of the Building Commissioner, which are in all respects hereby approved.

Section 2. That the funds for the purposes of this Resolution have been appropriated and shall be paid from the Recreation Capital Improvement Fund.

Section 3. That it is found and determined that all formal actions of this Council concerning and relating to the adoption of this Resolution were adopted in an open meeting of this Council; and that all deliberations of the Council and any of its committees that resulted in such formal action were in meetings open to the public in compliance with all legal requirements.

Section 4. That this Resolution is hereby declared to be an emergency measure immediately necessary for the preservation of the public peace, health, safety and welfare of the City, and for the further reason that it is immediately necessary to authorize advertising for public bidding on this project in order to maintain and improve the City's facilities for the benefit and safety of its patrons, and to conserve public funds. Therefore, provided this Resolution receives the affirmative vote of two-thirds of all members elected to Council, it shall take effect and be in force immediately upon its passage and approval by the Mayor; otherwise from and after the earliest period allowed by law.

President of Council

Approved: _____
Mayor

Date Passed: _____

Date Approved: _____

CITY OF STRONGSVILLE
RESOLUTION NO. 2016 - 228
Page 2

	<u>Yea</u>	<u>Nay</u>
Carbone	_____	_____
Daymut	_____	_____
DeMio	_____	_____
Dooner	_____	_____
Schonhut	_____	_____
Short	_____	_____
Southworth	_____	_____

Attest: _____
Clerk of Council

RES
ORD. No. 2016-228 Amended: _____
1st Rdg. _____ Ref: _____
2nd Rdg. _____ Ref: _____
3rd Rdg. _____ Ref: _____

Pub Hrg. _____ Ref: _____
Adopted: _____ Defeated: _____

CITY OF STRONGSVILLE, OHIO

RESOLUTION NO. 2016 – 229

By: Mayor Perciak and Mr. Dooner

**A RESOLUTION ESTABLISHING A FUND TO BE KNOWN
AS THE HEALTH INSURANCE RESERVE FUND, NO. 661.**

BE IT RESOLVED BY THE COUNCIL OF THE CITY OF STRONGSVILLE,
COUNTY OF CUYAHOGA AND STATE OF OHIO:

Section 1. That, pursuant to the provisions of Ohio Revised Code Section 5705.13(C) and the City's Home Rule authority, there shall be and is hereby established an internal service fund known as the Health Insurance Reserve Fund, No. 661.

Section 2. That the Director of Finance be and is hereby authorized to utilize said Fund to account for monies charged to the General Fund, Special Revenue Funds, and the Enterprise Fund of the City for health insurance claims, administration fees, stop-loss insurance and related Affordable Care Act (ACA) taxes.

Section 3. That the Director of Finance be and is hereby further authorized and directed to certify a copy of this Resolution to the Auditor of State for approval if required pursuant to Ohio Revised Code Section 5705.12.

Section 4. That it is found and determined that all formal actions of this Council concerning and relating to the adoption of this Resolution were adopted in an open meeting of this Council, and that all deliberations of this Council, and any of its committees, that resulted in such formal action were in meetings open to the public in compliance with all legal requirements.

Section 5. That this Resolution shall take effect and be in force immediately upon its passage and approval by the Mayor.

President of Council

Approved: _____
Mayor

Date Passed: _____

Date Approved: _____

CITY OF STRONGSVILLE, OHIO
RESOLUTION NO. 2016 – 229
Page 2

	<u>Yea</u>	<u>Nay</u>
Carbone	_____	_____
Daymut	_____	_____
DeMio	_____	_____
Dooner	_____	_____
Schonhut	_____	_____
Short	_____	_____
Southworth	_____	_____

Attest: _____
Clerk of Council

RES
ORD. No. 2016-229 Amended: _____
1st Rdg. _____ Ref: _____
2nd Rdg. _____ Ref: _____
3rd Rdg. _____ Ref: _____

Pub Hrg. _____ Ref: _____
Adopted: _____ Defeated: _____

CITY OF STRONGSVILLE, OHIO

ORDINANCE NO. 2016 – 230

By: Mayor Perciak and All Members of Council

AN ORDINANCE AUTHORIZING THE MAYOR TO ENTER INTO A CONTRACT FOR A COMPREHENSIVE HEALTH BENEFITS PLAN FOR CITY EMPLOYEES FOR THE YEAR 2017, WITHOUT FURTHER PUBLIC BIDDING, AND DECLARING AN EMERGENCY.

WHEREAS, this Council, by and through Ordinance No. 2015-212, authorized the Mayor to enter into a contract with Medical Mutual of Ohio for a period of one (1) year expiring December 31, 2016 for a comprehensive health benefits plan for employees of the City; and

WHEREAS, for various reasons the insurance market continues to be in an unusual condition and is severely restricted with respect to underwriting of comprehensive health benefits plans for public employees, including hospitalization, major medical, dental, group life and other coverages; and

WHEREAS, the City previously entered into collective bargaining agreements with various employee bargaining groups, which agreements require that the City continue to provide comprehensive health benefit plans for such collective bargaining employees; and

WHEREAS, the Fedeli Group, the City's health insurance consultant has recommended that a new contract with Medical Mutual of Ohio for the furnishing of administrative services and stop-loss insurance coverage for the City of Strongsville's employee health coverage would be competitive, advantageous, and in the best interest of the City under current conditions.

NOW, THEREFORE, BE IT ORDAINED BY THE COUNCIL OF THE CITY OF STRONGSVILLE, COUNTY OF CUYAHOGA AND STATE OF OHIO, BY UNANIMOUS AFFIRMATIVE VOTE:

Section 1. That this Council finds and determines, as set out in Article V, Section 5 of the Charter, that there is an immediate and present emergency in the operation of all the Departments of the City of Strongsville, in that it is necessary to enter into a contract with Medical Mutual of Ohio in order to avoid a gap in comprehensive health benefits coverage for City employees, maintain reasonable health insurance protection with reasonable premiums and contributions by City employees, preserve the expenditure of funds in relation to health benefit plan coverage, and comply with the terms and conditions of the City's negotiated collective bargaining contracts.

Section 2. That, for the reasons aforesaid, the Mayor, Director of Finance and Human Resources Director be and are hereby authorized and directed to enter into and implement a contract with **MEDICAL MUTUAL OF OHIO** for the period of January 1, 2017 through December 31, 2017, for the furnishing of administrative services and stop-loss insurance coverage for the City of Strongsville’s employee health coverage, as reflected on Exhibit A, attached hereto, which includes hospitalization, major medical, dental, certain vision, prescription, health and wellness, and other coverages on file with the Human Resources Director and/or Director of Finance, and all in a form to be approved by the Director of Finance and Law Director.

Section 3. That the funds necessary for the aforesaid contract will be appropriated and shall be paid from the General Fund, Sanitary Sewer Fund, Fire Levy Fund, Multi-Purpose Complex Fund, the Street Construction, Maintenance & Repair Fund, Community Diversion Fund, and Health Insurance Reserve Fund.

Section 4. That it is found and determined that all formal actions of this Council concerning and relating to the adoption of this Ordinance were adopted in an open meeting of this Council; and that all deliberations of this Council, and any of its committees, that resulted in such formal action were in meetings open to the public in compliance with all legal requirements.

Section 5. That this Ordinance is hereby declared to be an emergency measure necessary for the immediate preservation of the public peace, property, health, safety and welfare of the City, and for the further reason that it is immediately necessary to establish the aforesaid benefit plan in order to provide continuity of health benefits to City employees, comply with existing and future labor agreement requirements, and conserve public funds. Therefore, provided this Ordinance receives the unanimous affirmative vote of all members elected to Council, it shall take effect and be in force immediately upon its passage and approval by the Mayor.

_____ Approved: _____
 President of Council Mayor

Date Passed: _____ Date Approved: _____

	<u>Yea</u>	<u>Nay</u>
Carbone	_____	_____
Daymut	_____	_____
DeMio	_____	_____
Dooner	_____	_____
Schonhut	_____	_____
Short	_____	_____
Southworth	_____	_____

Attest: _____
 Clerk of Council

ORD. No. 2016-230 Amended: _____
 1st Rdg. _____ Ref: _____
 2nd Rdg. _____ Ref: _____
 3rd Rdg. _____ Ref: _____

 Pub Hrg. _____ Ref: _____
 Adopted: _____ Defeated: _____

CITY OF STRONGSVILLE
Proposed Rates Effective: 1/1/2017 through 12/31/2017
Minimum Premium Proposal 3.A

Minimum Premium based on 110% of Expected Paid Claims and \$100,000 Specific Stop Loss; No Loss Carry Forward
 Specific stop loss covers Medical & Rx claims.

	<u>Enrollment</u>	<u>Deposit Liability</u>	<u>Terminal Liability</u>	<u>Stop Loss</u>	<u>Administration Fee</u>	<u>Cobra Rates</u>
Medical Plan 1- 3 Tier \$100/350/500						
Single	51	\$397.35	\$63.65	\$78.82	N/A	\$519.26
Family	232	\$993.38	\$159.13	\$197.05	N/A	\$1,298.15
Composite PEPM	283	N/A	N/A	N/A	\$63.72	
Annual Projection		\$3,008,748	\$481,972	\$596,825	\$216,393	
Drug Plan 1 - \$20/40/60 2x mo						
Single	51	\$144.05	\$6.33	\$5.03	N/A	\$145.38
Family	232	\$358.40	\$15.75	\$12.51	N/A	\$361.71
Composite PEPM	283	N/A	N/A	N/A	\$8.09	
Annual Projection		\$1,085,944	\$47,722	\$37,906	\$27,474	
Dental Plan 1 - PPO Dental						
Single	51	\$23.95	\$2.27	\$0.88	N/A	\$26.94
Family	232	\$59.92	\$5.68	\$2.20	N/A	\$67.40
Composite PEPM	283	N/A	N/A	N/A	\$4.96	
Annual Projection		\$181,475	\$17,202	\$6,663	\$16,844	
Vision Plan 1 - Schedule						
Single	51	\$2.41	\$0.41	\$0.09	N/A	\$3.18
Family	232	\$6.03	\$1.03	\$0.23	N/A	\$7.96
Composite PEPM	283	N/A	N/A	N/A	\$1.18	
Annual Projection		\$18,262	\$3,118	\$695	\$4,007	
Annual Projection for All Benefits		\$4,294,429	\$550,014	\$642,089	\$264,718	

1. Specific Stop Loss covers claims incurred January 1, 2017 through December 31, 2017 and paid January 1, 2017 through December 31, 2017. Annual specific reimbursement maximum is unlimited per covered person.

2. Aggregate Stop Loss covers claims incurred January 1, 2017 through December 31, 2017 and paid January 1, 2017 through December 31, 2017. Annual aggregate reimbursement maximum is \$1,000,000.

EXHIBIT A