



City of Strongsville

16099 Foltz Parkway
Strongsville, Ohio 44149-5598
Phone: 440-580-3110
Council Office Fax: 440-572-1648
www.strongsville.org

March 2, 2017

MEETING NOTICE

City Council

Michael J. Daymut
Ward 1

Matthew A. Schonhut
Ward 2

James E. Carbone
Ward 3

Gordon C. Short
Ward 4

Joseph C. DeMio
At-Large

Kenneth M. Dooner
At-Large

Duke Southworth
At-Large

Aimee Pientka, MMC
Clerk of Council

Tiffany Mekeel, CMC
Assistant Clerk of Council

City Council has scheduled the following meetings for **Monday, March 6, 2017**, to be held in the Caucus Room and the Council Chamber at the **Mike Kalinich Sr. City Council Chamber, 18688 Royalton Road**:

Caucus will begin at 7:30 p.m. All committees listed will meet immediately following the previous committee:

7:30 P.M. Planning, Zoning and Engineering Committee will meet to discuss Ordinance Nos. 2016-225, 2017-001 and Resolution Nos. 2017-029 and 2017-030.

Recreation and Community Services Committee will meet to discuss Ordinance No. 2017-031.

Public Service and Conservation Committee will meet to discuss Ordinance No. 2017-032 and Resolution Nos. 2017-033, 2017-034, 2017-035, 2017-036 and 2017-037.

Public Safety and Health Committee will meet to discuss Ordinance No. 2017-038.

Economic Development will meet to discuss items pertinent to the committee.

8:00 P.M. Regular Council Meeting

Any other matters that may properly come before this Council may also be discussed.

BY ORDER OF THE COUNCIL:

Aimee Pientka, MMC
Clerk of Council





STRONGSVILLE CITY COUNCIL REGULAR MEETING
MONDAY, MARCH 6, 2017 AT 8:00 P.M.
Mike Kalinich Sr. City Council Chamber
18688 Royalton Road, Strongsville, Ohio



AGENDA

1. CALL TO ORDER:
2. PLEDGE OF ALLEGIANCE:
3. CERTIFICATION OF POSTING:
4. ROLL CALL:
5. COMMENTS ON MINUTES:
 - *Council Meeting – February 21, 2017*
6. APPOINTMENTS, CONFIRMATIONS, AWARDS AND RECOGNITION:
 - *Mayor's re-appointment of John J. Rusnov to a four (4) year term on the City's Board of Zoning Appeals, effective March 15, 2017, and expiring on March 14, 2021.*
 - *Mayor's re-appointment of Thomas E. Smeader to a four (4) year term on the City's Board of Zoning Appeals, effective March 15, 2017, and expiring on March 14, 2021.*
7. PUBLIC HEARING:
 - Ordinance No. 2016-225 by Mr. Daymut. AN ORDINANCE AMENDING THE ZONING MAP OF THE CITY OF STRONGSVILLE ADOPTED BY SECTION 1250.03 OF TITLE SIX, PART TWELVE OF THE CODIFIED ORDINANCES OF STRONGSVILLE TO CHANGE THE ZONING CLASSIFICATION OF CERTAIN PROPERTY LOCATED AT 21487 ROYALTON ROAD (PORTIONS OF PPNs 393-03-007 AND 393-03-008) IN THE CITY OF STRONGSVILLE, FROM GI (GENERAL INDUSTRIAL) CLASSIFICATION TO GB (GENERAL BUSINESS) CLASSIFICATION, AND DECLARING AN EMERGENCY. *First reading and referred to Planning Commission 12-05-16. Tabled by Planning Commission 12-15-16. Unfavorable recommendation by the Planning Commission 01-12-17. Second reading 01-17-17. Public hearing 03-06-17.*
 - Ordinance No. 2017-001 by Mayor Perciak and Mr. Daymut. AN ORDINANCE AMENDING SECTION 1262.04 OF CHAPTER 1262 OF TITLE SIX OF PART TWELVE-PLANNING AND ZONING CODE OF THE CODIFIED ORDINANCES OF THE CITY OF STRONGSVILLE REGARDING CERTAIN MAIN USES IN THE GENERAL INDUSTRIAL (GI) DISTRICT, AND DECLARING AN EMERGENCY. *First reading and referred to Planning Commission 01-03-17. Favorable recommendation by the Planning Commission 01-12-17. Second reading 01-17-17. Public hearing 03-06-17.*

8. REPORTS OF COUNCIL COMMITTEE:

- SCHOOL BOARD – Mr. Dooner:
- SOUTHWEST GENERAL HEALTH SYSTEM – Mr. Carbone:
- BUILDING AND UTILITIES – Mr. Schonhut:
- COMMUNICATIONS AND TECHNOLOGY – Mr. Schonhut:
- ECONOMIC DEVELOPMENT– Mr. Daymut:
- FINANCE – Mr. Short:
- PLANNING, ZONING AND ENGINEERING – Mr. Daymut:
- PUBLIC SAFETY AND HEALTH – Mr. DeMio:
- PUBLIC SERVICE AND CONSERVATION – Mr. Carbone:
 - A motion to note and approve the owner's designation of wishes for interments in the Strongsville Municipal Cemetery, Section C, Lot # 131, Grave E.
 - A motion to note and approve the owners' designation of wishes for interments in the Strongsville Municipal Cemetery, Section C, Lot # 181, Graves F & H.
- RECREATION AND COMMUNITY SERVICES – Mr. Southworth:
- COMMITTEE-OF-THE-WHOLE – Mr. Dooner:

9. REPORTS AND COMMUNICATIONS FROM THE MAYOR, DIRECTORS OF DEPARTMENTS AND OTHER OFFICERS:

- MAYOR PERCIAK:
- FINANCE DEPARTMENT:
- LAW DEPARTMENT:

10. AUDIENCE PARTICIPATION:

11. ORDINANCES AND RESOLUTIONS:

- Ordinance No. 2016-225 by Mr. Daymut. AN ORDINANCE AMENDING THE ZONING MAP OF THE CITY OF STRONGSVILLE ADOPTED BY SECTION 1250.03 OF TITLE SIX, PART TWELVE OF THE CODIFIED ORDINANCES OF STRONGSVILLE TO CHANGE THE ZONING CLASSIFICATION OF CERTAIN PROPERTY LOCATED AT 21487 ROYALTON ROAD (PORTIONS OF PPNs 393-03-007 AND 393-03-008) IN THE CITY OF STRONGSVILLE, FROM GI (GENERAL INDUSTRIAL) CLASSIFICATION TO GB (GENERAL BUSINESS) CLASSIFICATION, AND DECLARING AN EMERGENCY. *First reading and referred to Planning Commission 12-05-16. Tabled by Planning Commission 12-15-16. Unfavorable recommendation by the Planning Commission 01-12-17. Second reading 01-17-17. Public hearing 03-06-17.*
- Ordinance No. 2017-001 by Mayor Perciak and Mr. Daymut. AN ORDINANCE AMENDING SECTION 1262.04 OF CHAPTER 1262 OF TITLE SIX OF PART TWELVE-PLANNING AND ZONING CODE OF THE CODIFIED ORDINANCES OF THE CITY OF STRONGSVILLE REGARDING CERTAIN MAIN USES IN THE GENERAL INDUSTRIAL (GI) DISTRICT, AND DECLARING AN EMERGENCY. *First reading and referred to Planning Commission 01-03-17. Favorable recommendation by the Planning Commission 01-12-17. Second reading 01-17-17. Public hearing 03-06-17.*
- Resolution No. 2017-029 by Mr. Daymut. A RESOLUTION CONFIRMING PLANNING COMMISSION APPROVAL OF THE FINAL SITE PLAN FOR THE REMOVAL OF THREE EXISTING ANTENNAS, THE ADDITION OF THREE (3) NEW ANTENNAS AND THREE REMOTE RADIO HEADS (RRHs) FOR THE CO-LOCATION ON AN EXISTING TELECOMMUNICATIONS TOWER, ON CITY-OWNED PROPERTY LOCATED AT 16099 FOLTZ PARKWAY (PPN 393-12-002 AND 393-10-001), IN THE CITY OF STRONGSVILLE, AND DECLARING AN EMERGENCY.
- Resolution No. 2017-030 by Mr. Daymut. A RESOLUTION APPROVING AN AMENDED DEVELOPMENT PLAN FOR THE GREAT ESCAPE PLAZA TO PERMIT CONSTRUCTION OF A DRIVE-THRU RESTAURANT, LOCATED AT 17200 ROYALTON ROAD, IN THE CITY OF STRONGSVILLE; AND DECLARING AN EMERGENCY.
- Ordinance No. 2017-031 by Mayor Perciak and Mr. Southworth. AN ORDINANCE AUTHORIZING THE MAYOR TO ENTER INTO A CONTRACT FOR THE COMPLETE RENOVATION OF FOUR LOCKER ROOM/RESTROOM FACILITIES AT THE CITY OF STRONGSVILLE WALTER F. EHRNFELT RECREATION & SENIOR CENTER, AND DECLARING AN EMERGENCY.
- Ordinance No. 2017-032 by Mr. Carbone. AN ORDINANCE AUTHORIZING THE DISPOSAL OF A DEPARTMENT OF PUBLIC SERVICE VEHICLE AND CERTAIN EQUIPMENT NO LONGER NEEDED FOR ANY MUNICIPAL PURPOSE, AND DECLARING AN EMERGENCY.
- Resolution No. 2017-033 by Mayor Perciak and Mr. Carbone. A RESOLUTION AUTHORIZING THE MAYOR TO ADVERTISE FOR BIDS FOR SWEEPING OF STREETS FOR 2017 AND 2018, WITHIN THE CITY OF STRONGSVILLE.

- Resolution No. 2017-034 by Mayor Perciak and Mr. Carbone. A RESOLUTION AUTHORIZING THE MAYOR TO ADVERTISE FOR BIDS FOR MATERIALS AND SERVICES IN CONNECTION WITH THE PAINT STRIPING OF CERTAIN STREETS AND HIGHWAYS FOR 2017 AND 2018, WITHIN THE CITY OF STRONGSVILLE.
- Resolution No. 2017-035 by Mayor Perciak and Mr. Carbone. A RESOLUTION AUTHORIZING THE MAYOR TO ADVERTISE FOR BIDS FOR THE PURCHASE OF VEHICLE AND EQUIPMENT TIRES AND RELATED TIRE SERVICES FOR 2017 AND 2018, TO BE USED BY THE SERVICE DEPARTMENT OF THE CITY OF STRONGSVILLE.
- Resolution No. 2017-036 by Mayor Perciak and Mr. Carbone. A RESOLUTION AUTHORIZING THE MAYOR TO ADVERTISE FOR BIDS FOR THE PURCHASE OF ASPHALT MATERIALS FOR USE DURING 2017 AND 2018, BY THE SERVICE DEPARTMENT OF THE CITY OF STRONGSVILLE.
- Resolution No. 2017-037 by Mayor Perciak and Mr. Carbone. A RESOLUTION AUTHORIZING THE MAYOR TO ADVERTISE FOR BIDS FOR THE PURCHASE OF GENERAL PAVEMENT SERVICES FOR 2017 FOR USE BY THE SERVICE DEPARTMENT OF THE CITY OF STRONGSVILLE.
- Ordinance No. 2017-038 by Mr. DeMio. AN ORDINANCE AUTHORIZING THE MAYOR TO ENTER INTO A CONTRACT FOR THE PURCHASE OF A NEW 2017 FORD EXPEDITION SSV EXTENDED LENGTH WITH MARKED VEHICLE LIGHTING PACKAGE, FOR USE BY THE CITY'S FIRE DEPARTMENT, WITHOUT PUBLIC BIDDING, AND DECLARING AN EMERGENCY.

12. COMMUNICATIONS, PETITIONS AND CLAIMS:

13. MISCELLANEOUS BUSINESS:

14. ADJOURNMENT:

CITY OF STRONGSVILLE, OHIO

ORDINANCE NO. 2016 – 225

By: Mr. Daymut

AN ORDINANCE AMENDING THE ZONING MAP OF THE CITY OF STRONGSVILLE ADOPTED BY SECTION 1250.03 OF TITLE SIX, PART TWELVE OF THE CODIFIED ORDINANCES OF STRONGSVILLE TO CHANGE THE ZONING CLASSIFICATION OF CERTAIN PROPERTY LOCATED AT 21487 ROYALTON ROAD (PORTIONS OF PPNs 393-03-007 AND 393-03-008) IN THE CITY OF STRONGSVILLE, FROM GI (GENERAL INDUSTRIAL) CLASSIFICATION TO GB (GENERAL BUSINESS) CLASSIFICATION, AND DECLARING AN EMERGENCY.

BE IT ORDAINED BY THE COUNCIL OF THE CITY OF STRONGSVILLE, COUNTY OF CUYAHOGA, AND STATE OF OHIO:

Section 1. That the Zoning Map of the City of Strongsville, adopted by Section 1250.03 of Title Six, Part Twelve of the Codified Ordinances of Strongsville, be amended to change the zoning classification of certain property located at 21487 Royalton Road (portions of PPNs 393-03-007 and 393-03-008), from GI (General Industrial) classification to GB (General Business) classification, which property is more fully described and depicted in Exhibits "A" and "B", attached hereto and incorporated herein as if fully rewritten.

Section 2. That the Clerk of Council is hereby authorized to cause the necessary change on the Zoning Map to be made in order to reflect the zoning change in classification as provided in this Ordinance.

Section 3. That it is found and determined that all formal actions of this Council concerning and relating to the adoption of this Ordinance were adopted in an open meeting of this Council; and that all deliberations of this Council, and any of its committees, that resulted in such formal action were in meetings open to the public in compliance with all legal requirements.

Section 4. That this Ordinance is hereby declared to be an emergency measure necessary for the immediate preservation of the public peace, property, health, safety and welfare of the City, and for the further reason that it is immediately necessary to rezone such property in order to provide for the orderly development of lots and lands within the City, to afford the applicant an opportunity to submit plans and commence construction as weather permits, to enhance economic development within the City, and to conserve public funds. Therefore, provided this Ordinance receives the affirmative vote of two-thirds of all members elected to Council, it shall take effect and be in force immediately upon its passage and approval by the Mayor; otherwise from and after the earliest period allowed by law.

CITY OF STRONGSVILLE, OHIO
ORDINANCE NO. 2016 - 225
Page 2

First Reading: December 5, 2016
Second Reading: January 17, 2017
Third Reading: _____
Public Hearing: March 6, 2017

Referred to Planning Commission
December 5, 2016
Unfavorable recommendation by PC
Approved: 01-12-17

President of Council

Approved: _____
Mayor

Date Passed: _____

Date Approved: _____

	<u>Yea</u>	<u>Nay</u>
Carbone	_____	_____
Daymut	_____	_____
DeMio	_____	_____
Dooner	_____	_____
Schonhut	_____	_____
Short	_____	_____
Southworth	_____	_____

Attest: _____
Clerk of Council

ORD. No. 2016-225 Amended: _____
1st Rdg. 12-5-16 Ref: PC/PZE
2nd Rdg. 1-17-17 Ref: PZE
3rd Rdg. _____ Ref: _____

Unfavorable recommendation by PC
01-12-17

Pub Hrg. 3-6-17 Ref: _____
Adopted: _____ Defeated: _____

PETITION FOR ZONING CHANGE

Ordinance Number: 2016-225

To the Council of the City of Strongsville, County of Cuyahoga, State of Ohio:

I/We, the undersigned owner(s) of the property set above our names on the Property Description Form attached to this document, hereby petition your Honorable Body that said property be changed from a class GI use to a class GB use.

Such change is necessary for the preservation and enjoyment of a substantial property right because: It will fill a commercial need currently not being met in the community.
It will also begin the clean up of a property that community leaders feel is needed. Dividing this parcel into multiple uses is logical due to the properties shape

Such change will not be materially detrimental to the public welfare nor to the property of other persons located in the vicinity because: This parcel will combine multiple curb cuts down to a single access point, therefore the zoning to the east is industrial and to the west is railroad tracks so no negative impact on either property

Please list other supporting documents (if any) which accompany this petition:

- A tractor Supply Site Plan
- Boundary Survey of entire 13acres
- _____

THE PROPOSED USE OF THE PROPERTY IS: A Tractor Supply Company
Retail store.

Name, address and **telephone number** of applicant or applicant's agent:

Name: Keith Carter

Address: 1076 Summitt Drive Middletown, OH 45042

Telephone Number: 513-292-5837

Frank Jarama / J. J. Jarama Members
Signature of Owner(s) Jarama Land, LLC

State of Ohio)
County of Cuyahoga)

Sworn to and subscribed in my presence this 21st day of November, 2016.



Pamela J. O'Toole
Notary Public PAMELA J. O'TOOLE

My commission expires: _____
NOTARY PUBLIC • STATE OF OHIO
Recorded in Cuyahoga County
My commission expires Apr. 29, 2021

* Please pay particular attention to the details in item number 4 on page one. The United States property owners must be prepared by a title insurance company. Please provide a cover letter from the title insurance company verifying that said list was prepared by them.

PROPERTY DESCRIPTION FORM

Ordinance Number: 2016-225

The following described property is that property for which a change is being requested in the attached Petition for Zoning Change and which is hereby incorporated into and made part of said petition:

Address of Property: 21487 Royalton Road Strongsville, OH 44149

Permanent Parcel No.: 393-03-007 + 393-03-008 + 393-05-008

The property is bounded by the following streets: (indicate direction; i.e., north, south, etc.) The southern property boundary is Royalton Road

Number and type of buildings which now occupy property (if any): There is an existing residential home with a garage and an existing commercial landscape office w/out buildr

Acreage: entire site is 13 acres. We are rezoning 3.753

Said property (has) (had) the following deed restrictions affecting the use thereof (attach copy): None

Said deed restrictions (will) (have) expire(d) on: N/A

Said property is presently under lease or otherwise encumbered as follows: Residential home is month to month and Landscape company is on a short term lease

Owner(s)	Percent of Ownership:
1. <u>JASON FEISCONE</u>	<u>50%</u> %
2. <u>FRANK JARAM</u>	<u>50%</u> %
3. _____	_____ %

Frank Jaram / J. Feisone Members
Signature of Owner(s) Jaram & Land, LLC

State of Ohio)
County of Cuyahoga)

Sworn to and subscribed to in my presence this 21st day of September, 2016.



Pamela J. O'Toole
Notary Public

My commission expires _____
PAMELA J. O'TOOLE
NOTARY PUBLIC • STATE OF OHIO
Recorded in Cuyahoga County
My commission expires Apr. 29, 2021

* Please pay particular attention to the details in item number 4 on page one. The certified list of property owners must be prepared by a title insurance company. Please provide a cover letter from the title insurance company verifying that said list was prepared by them.

LEGAL DESCRIPTION

BEING A TRACT OF LAND OWNED BY JARONE LAND COMPANY LLC. AS DESCRIBED IN AFN 201007300211 OF THE CUYAHOGA COUNTY DEED RECORDS, SITUATE IN THE CITY OF STRONGSVILLE, COUNTY OF CUYAHOGA, STATE OF OHIO, AND KNOWN AS BEING PART OF ORIGINAL STRONGSVILLE TOWNSHIP LOT NUMBER 85, OHIO AND BEING MORE PARTICULARLY DESCRIBED AS FOLLOWS:

Commencing for reference at a monument box found with a 5/8" iron pinned capped "Skonieczny, S-6356" at the northwest corner of Out Lot 85 as Part of the Original Strongville Township Lots;

thence, South 88°-35'-59" East, 1103.99 feet, along the centerline of State Route 82, also known as Royalton Road to the northeast corner of a tract of land owned by Anna L. St. Peter as described in Volume 15676, Page 451;

thence, South 00°-33'-24" West, 40.00 feet, along the east line of said St. Peter tract to an iron pin with cap found on the south right-of-way line of State Route 82;

thence, South 88°-35'-58" East, 200.00 feet, along the south right-of-way line of State Route 82 to a point, and being the principal place of beginning of the tract herein described;

thence, South 88°-35'-58" East, 100.00 feet, to a point;

thence, South 00°-33'-24" West, 545.00 feet, to a point;

thence, North 88°-35'-58" West, 100.00 feet, to a point;

thence, North 00°-33'-24" East, 545.00 feet, to the principal place of beginning.

Containing 1.251 acres more or less and all being subject to any legal highway and easements of record.

The bearings are assumed and used to denote angles only.

The above description was prepared by Allen J. Bertke, Ohio Professional Surveyor Number 8629.

This legal description is to be used for Zoning approval only and not for property transfer.

This survey was prepared based on a survey performed by Bramhall Engineering and Surveying Co., Inc. in 2011. No field work was performed in preparing this exhibit and legal description.

EXHIBIT A

**SITUATED IN THE CITY OF STRONGSVILLE, COUNTY OF CUYAHOGA, STATE OF OHIO
AND BEING PART OF ORIGINAL STRONGSVILLE TOWNSHIP LOT NUMBER 85**

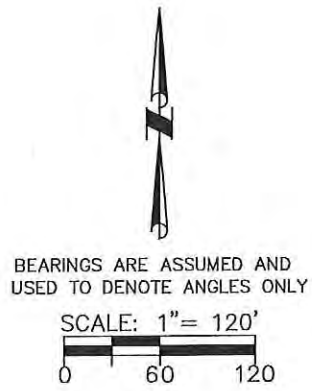
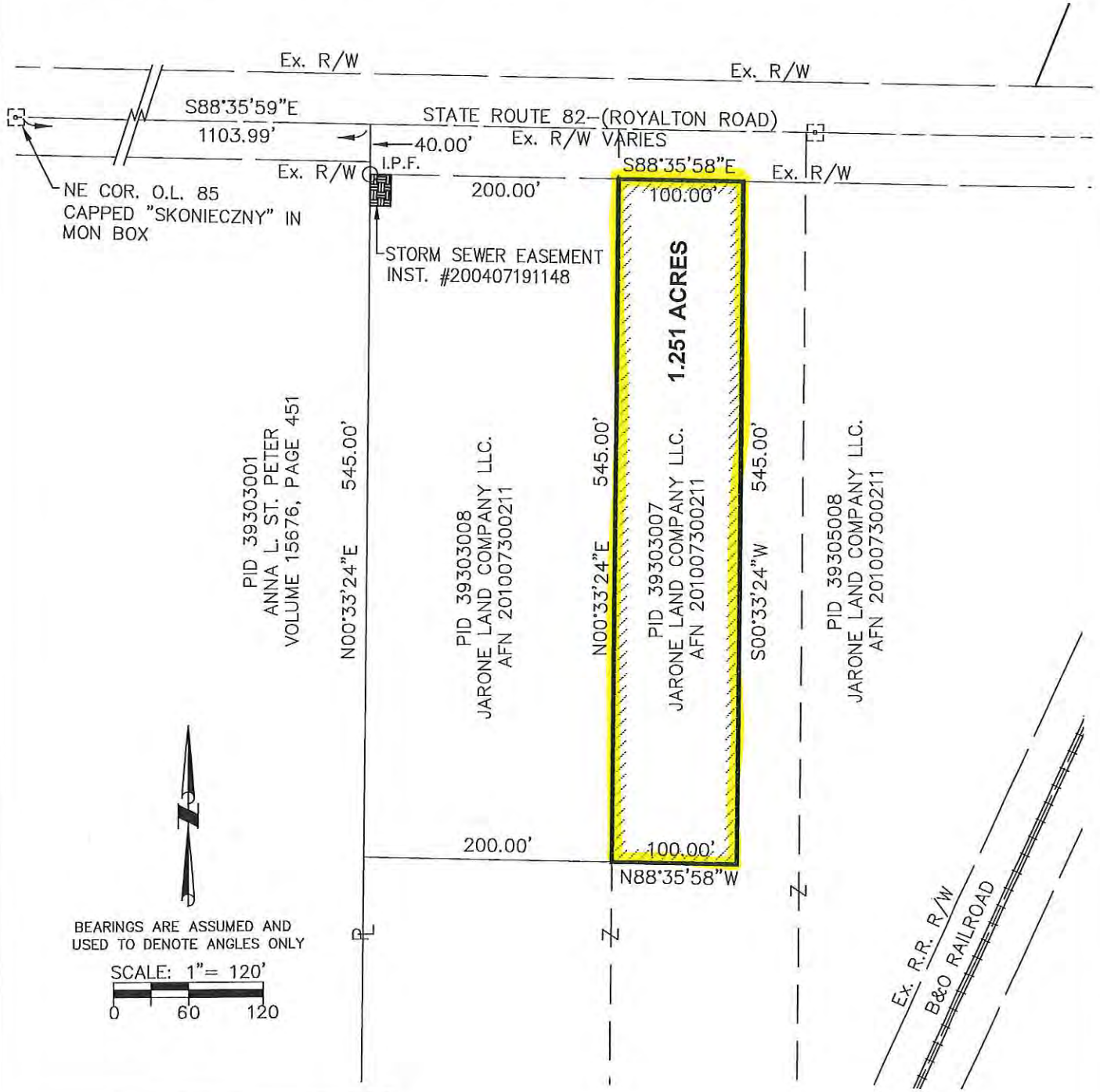

SIDNEY, OHIO 937.497.0200
LOVELAND, OHIO 513.239.8554
PORTLAND, INDIANA 260.766.2500
www.CHOICEONEENGINEERING.com

LEGEND

- I.P.F. IRON PIN FOUND
- ☒ MONUMENT BOX W/IP FOUND

LEGAL DESCRIPTION

BEING A TRACT OF LAND OWNED BY JARONE LAND COMPANY LLC. AS DESCRIBED IN AFN 201007300211 OF THE CUYAHOGA COUNTY DEED RECORDS, SITUATE IN THE CITY OF STRONGSVILLE, COUNTY OF CUYAHOGA, STATE OF OHIO, AND KNOWN AS BEING PART OF ORIGINAL STRONGSVILLE TOWNSHIP LOT NUMBER 85, OHIO AND BEING MORE PARTICULARLY DESCRIBED AS FOLLOWS:

Commencing for reference at a monument box found with a 5/8" iron pinned capped "Skonieczny, S-6356" at the northwest corner of Out Lot 85 as Part of the Original Strongsville Township Lots;

thence, South 88°-35'-59" East, 1103.99 feet, along the centerline of State Route 82, also known as Royalton Road to the northeast corner of a tract of land owned by Anna L. St. Peter as described in Volume 15676, Page 451;

thence, South 00°-33'-24" West, 40.00 feet, along the east line of said St. Peter tract to an iron pin with cap found on the south right-of-way line of State Route 82, and being the principal place of beginning of the tract herein described;

thence, South 88°-35'-58" East, 200.00 feet, along the south right-of-way line of State Route 82 to a point;

thence, South 00°-33'-24" West, 545.00 feet, to a point;

thence, North 88°-35'-58" West, 200.00 feet, to a point on the east line of said St. Peter tract;

thence, North 00°-33'-24" East, 545.00 feet, along the east of said St. Peter tract to the principal place of beginning.

Containing 2.502 acres more or less and all being subject to any legal highway and easements of record.

The bearings are assumed and used to denote angles only.

The above description was prepared by Allen J. Bertke, Ohio Professional Surveyor Number 8629.

This legal description is to be used for Zoning approval only and not for property transfer.

This survey was prepared based on a survey performed by Bramhall Engineering and Surveying Co., Inc. in 2011. No field work was performed in preparing this exhibit and legal description.

EXHIBIT B

**SITUATED IN THE CITY OF STRONGSVILLE, COUNTY OF CUYAHOGA, STATE OF OHIO
AND BEING PART OF ORIGINAL STRONGSVILLE TOWNSHIP LOT NUMBER 85**

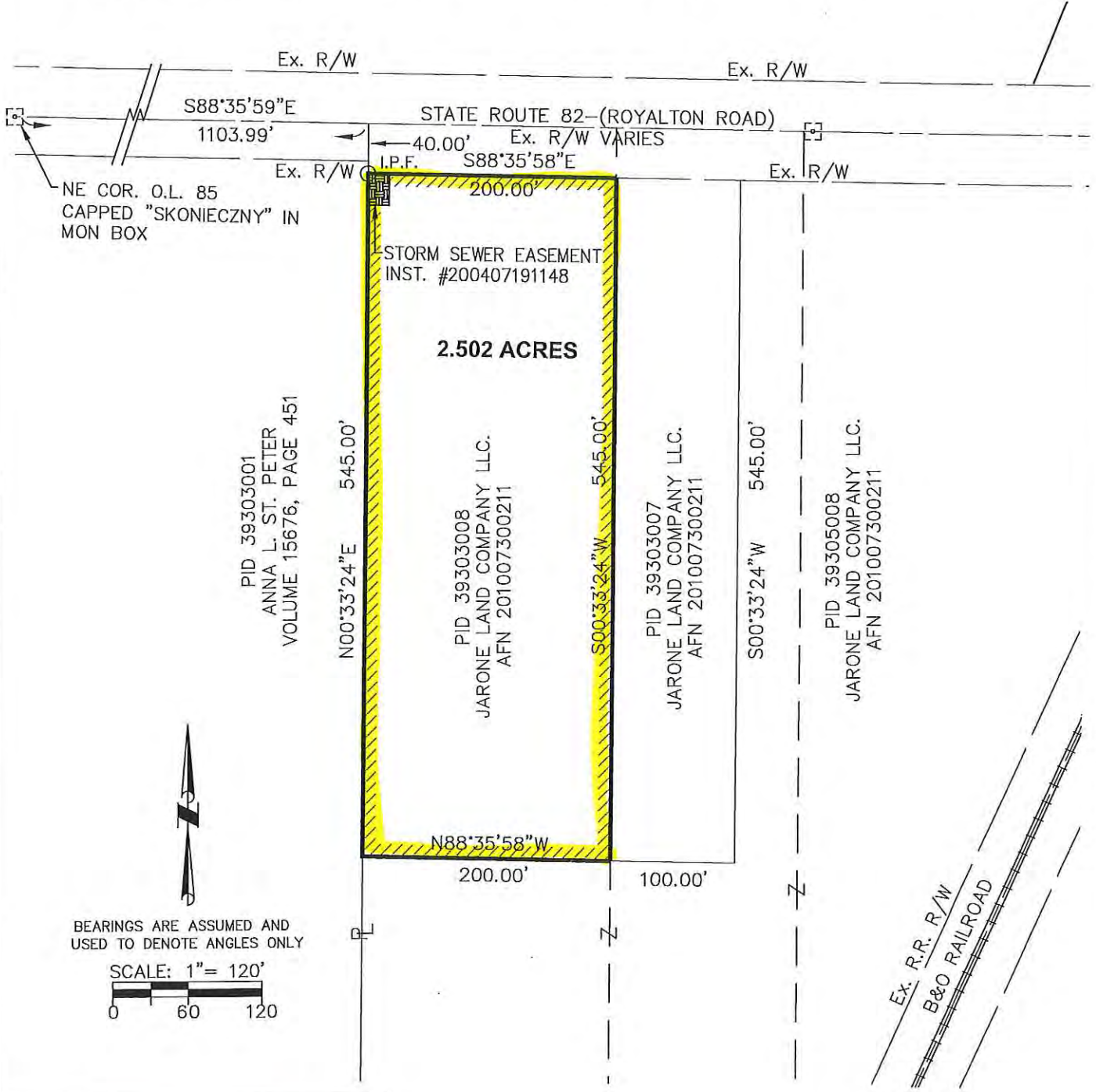

SIDNEY, OHIO 937.497.0200
LOVELAND, OHIO 513.239.8554
PORTLAND, INDIANA 260.766.2500
www.CHOICEONEENGINEERING.com

LEGEND

- I.P.F. IRON PIN FOUND
- ⊠ MONUMENT BOX W/IP FOUND

CITY OF STRONGSVILLE
OFFICE OF THE COUNCIL

MEMORANDUM

TO: Ken Mikula, City Engineer

FROM: Aimee Pientka, Clerk of Council

DATE: November 21, 2016

SUBJECT: Rezoning Application
Jason Friscone and Frank Jaram; Owners
PPNs: 393-03-007 (portion) and 393-03-008 (portion)
Address: 21487 Royalton Road
From General Industrial (GI) to General Business (GB)

Please check the legal description on the attached application for rezoning and, if correct, please forward to the Law Director so he may prepare legislation for Council to consider.

Thank you.

AKP
Attachments

cc: Thomas P. Perciak, Mayor
Neal Jamison, Law Director
Daniel J. Kolick, Assistant Law Director
George Smerigan, City Planner
Brent Painter, Economic Development Director
All Members of Council
Carol Opera, Planning Commission Secretary

CITY OF STRONGSVILLE
OFFICE OF THE COUNCIL

MEMORANDUM

TO: Planning Commission
FROM: Tiffany Mekeel, Assistant Clerk of Council
DATE: December 6, 2016
SUBJECT: Referral from Council: Ordinance No. 2016-225

At its regular meeting of December 5, 2016, City Council referred the following Ordinance to the Planning Commission for its report and recommendation thereon:

- Ordinance No. 2016-225 by Mr. Daymut. AN ORDINANCE AMENDING THE ZONING MAP OF THE CITY OF STRONGSVILLE ADOPTED BY SECTION 1250.03 OF TITLE SIX, PART TWELVE OF THE CODIFIED ORDINANCES OF STRONGSVILLE TO CHANGE THE ZONING CLASSIFICATION OF CERTAIN PROPERTY LOCATED AT 21487 ROYALTON ROAD (PORTIONS OF PPNs 393-03-007 and 393-03-008) IN THE CITY OF STRONGSVILLE, FROM GI (GENERAL INDUSTRIAL) CLASSIFICATION TO GB (GENERAL BUSINESS) CLASSIFICATION, AND DECLARING AN EMERGENCY.

A copy of the ordinance is attached for Planning Commission review.

TAM
Attachment

MEMORANDUM

TO: Aimee Pientka, Council Clerk
Neal Jamison, Law Director

FROM: Carol Oprea, Administrative Assistant, Boards & Commissions

SUBJECT: Referrals to Council

DATE: December 16, 2016

Please be advised that at its meeting of December 15, 2016, the Strongsville Planning Commission Tabled the following;

ORDINANCE 2016-225

An Ordinance Amending the Zoning Map of the City of Strongsville Adopted by Section 1250.03 of Title Six, Part Twelve of the Codified Ordinances of Strongsville to change the Zoning Classification of certain property located at 21487 Royalton Road (Portions of PPN's 393-03-007 and 393-03-008) in the City of Strongsville from GI (General Industrial) Classification to GB (General Business) Classification and Declaring an Emergency.

MEMORANDUM

TO: Aimee Pientka, Council Clerk
Neal Jamison, Law Director

FROM: Carol Oprea, Administrative Assistant, Boards & Commissions

SUBJECT: Referrals to Council

DATE: January 13, 2017

Please be advised that at its meeting of January 12, 2017, the Strongsville Planning Commission Denied the following;

ORDINANCE 2016-225

An Ordinance Amending the Zoning Map of the City of Strongsville Adopted by Section 1250.03 of Title Six, Part Twelve of the Codified Ordinances of Strongsville to change the Zoning Classification of certain property located at 21487 Royalton Road (Portions of PPN's 393-03-007 and 393-03-008) in the City of Strongsville from GI (General Industrial) Classification to GB (General Business) Classification and Declaring an Emergency.

Also at that same meeting the Strongsville Planning Commission gave approval to the following;

ORDINANCE NO. 2017-001

An Ordinance Amending Section 1262.04 of Chapter 1262 of Title Six of Part Twelve Planning and Zoning Code of the Codified Ordinances of the City of Strongsville regarding certain Main Uses in the General Industrial (GI) District, and Declaring an Emergency.

CITY OF STRONGSVILLE, OHIO

ORDINANCE NO. 2017 – 001

By: Mayor Perciak and Mr. Daymut

AN ORDINANCE AMENDING SECTION 1262.04 OF CHAPTER 1262 OF TITLE SIX OF PART TWELVE-PLANNING AND ZONING CODE OF THE CODIFIED ORDINANCES OF THE CITY OF STRONGSVILLE REGARDING CERTAIN MAIN USES IN THE GENERAL INDUSTRIAL (GI) DISTRICT, AND DECLARING AN EMERGENCY.

BE IT ORDAINED BY THE COUNCIL OF THE CITY OF STRONGSVILLE, COUNTY OF CUYAHOGA AND STATE OF OHIO:

Section 1. That Section 1262.04(a)(4) of Chapter 1262 of Title Six of Part Twelve of the Codified Ordinances of the City of Strongsville be and is hereby amended to read in its entirety as follows:

1262.04 USE REGULATIONS; GENERAL INDUSTRIAL (GI) DISTRICT.

Buildings and land shall be used, and buildings shall be designed, erected, altered, moved and maintained, in whole or in part, in a General Industrial District, only for the uses set forth in the following schedules and regulations:

(a) Main Uses Permitted.

* * *

- (4) The following uses may be permitted provided a conditional use permit is granted in accordance with the standards set forth in Section 1242.07 of this Zoning Code.
- A. Bulk distribution station for gasoline and oil.
 - B. Day care facilities.
 - C. Wireless telecommunication facilities in accordance with the provisions of C.O. Chapter 1273.
 - D. The filling, sale and/or exchange of propane canisters.
 - E. **Facilities engaged in sales, leasing, and repair of agricultural equipment and machinery, sale of agricultural products, sale of livestock and pet supplies, and sale of related products provided that such facilities are located with frontage on a Major Arterial Street. Such facilities may have outdoor storage of equipment and machinery, provided that such outdoor storage is**

**behind the front setback line and in designated areas
 approved by the Planning Commission.**
 (~~Ord. 2013-075. Passed 2-18-14.~~)

* * *

Section 2. That it is found and determined that all formal actions of this Council concerning and relating to the adoption of this Ordinance were adopted in an open meeting of this Council, and that all deliberations of this Council, and any of its committees, that resulted in such formal action were in meetings open to the public in compliance with all legal requirements.

Section 3. That this Ordinance is hereby declared to be an emergency measure necessary for the immediate preservation of the public peace, property, health, safety and welfare of the City, and for the further reasons that it is necessary to provide for proper development and zoning of lots and lands within the City, and to facilitate economic development. Therefore, provided this Ordinance receives the affirmative vote of two-thirds of all members elected to Council, it shall take effect and be in force immediately upon its passage and approval by the Mayor; otherwise from and after the earliest period allowed by law.

First reading: January 3, 2017 Referred to Planning Commission
 Second reading: January 17, 2017 January 4, 2017
 Third reading: _____ Approved: Favorable recommendation
by PC 01-12-17
 Public Hearing: March 4, 2017

 President of Council Approved: _____
 Mayor

Date Passed: _____ Date Approved: _____

	<u>Yea</u>	<u>Nay</u>
Carbone	_____	_____
Daymut	_____	_____
DeMio	_____	_____
Dooner	_____	_____
Schonhut	_____	_____
Short	_____	_____
Southworth	_____	_____

Attest: _____
 Clerk of Council

ORD. No. 2017-001 Amended: _____
 1st Rdg. 01-03-17 Ref: PC/PZE
 2nd Rdg. 01-17-17 Ref: PZE
 3rd Rdg. _____ Ref: _____

 Pub Hrg. 3-6-17 Ref: _____
 Adopted: _____ Defeated: _____

CITY OF STRONGSVILLE
OFFICE OF THE COUNCIL

MEMORANDUM

TO: Planning Commission
FROM: Aimee Pientka, Clerk of Council
DATE: January 4, 2017
SUBJECT: Referral from Council: Ordinance No. 2017-001

Please be advised that at its regular meeting of January 3, 2017, City Council referred the following Ordinances to the Planning Commission for its report and recommendation thereon:

- Ordinance No. 2017-001 by Mayor Perciak and Mr. Daymut. AN ORDINANCE AMENDING SECTION 1262.04 OF CHAPTER 1262 OF TITLE SIX OF PART TWELVE-PLANNING AND ZONING CODE OF THE CODIFIED ORDINANCES OF THE CITY OF STRONGSVILLE REGARDING CERTAIN MAIN USES IN THE GENERAL INDUSTRIAL (GI) DISTRICT, AND DECLARING AN EMERGENCY. *First reading and referred to Planning Commission 01-03-17.*

A copy of these Ordinances are attached for Planning Commission review.

AKP
Attachments

MEMORANDUM

TO: Aimee Pientka, Council Clerk
Neal Jamison, Law Director

FROM: Carol Oprea, Administrative Assistant, Boards & Commissions

SUBJECT: Referrals to Council

DATE: January 13, 2017

Please be advised that at its meeting of January 12, 2017, the Strongsville Planning Commission Denied the following;

ORDINANCE 2016-225

An Ordinance Amending the Zoning Map of the City of Strongsville Adopted by Section 1250.03 of Title Six, Part Twelve of the Codified Ordinances of Strongsville to change the Zoning Classification of certain property located at 21487 Royalton Road (Portions of PPN's 393-03-007 and 393-03-008) in the City of Strongsville from GI (General Industrial) Classification to GB (General Business) Classification and Declaring an Emergency.

Also at that same meeting the Strongsville Planning Commission gave approval to the following;

ORDINANCE NO. 2017-001

An Ordinance Amending Section 1262.04 of Chapter 1262 of Title Six of Part Twelve Planning and Zoning Code of the Codified Ordinances of the City of Strongsville regarding certain Main Uses in the General Industrial (GI) District, and Declaring an Emergency.

CITY OF STRONGSVILLE, OHIO

RESOLUTION NO. 2017 – 029

By: Mr. Daymut

A RESOLUTION CONFIRMING PLANNING COMMISSION APPROVAL OF THE FINAL SITE PLAN FOR THE REMOVAL OF THREE EXISTING ANTENNAS, THE ADDITION OF THREE (3) NEW ANTENNAS AND THREE REMOTE RADIO HEADS (RRHs) FOR THE CO-LOCATION ON AN EXISTING TELECOMMUNICATIONS TOWER, ON CITY-OWNED PROPERTY LOCATED AT 16099 FOLTZ PARKWAY (PPN 393-12-002 and 393-10-001), IN THE CITY OF STRONGSVILLE, AND DECLARING AN EMERGENCY.

WHEREAS, AT&T Mobility, through its agent, has submitted a final site plan to the Planning Commission for approval of the removal of three (3) existing antennas, the addition of three (3) new antennas and three (3) remote radio heads (RRHs) for the co-location on the existing telecommunications tower, on City-owned property located at 16099 Foltz Parkway, (PPN 393-12-002 and 393-10-001) zoned General Industrial; and

WHEREAS, Planning Commission has determined that the proposed modification does not substantially change the physical dimensions of the tower or base station for such facility; and

WHEREAS, the Commission approved said final site plan at its meeting of February 9, 2017.

NOW, THEREFORE, BE IT RESOLVED BY THE COUNCIL OF THE CITY OF STRONGSVILLE, COUNTY OF CUYAHOGA, STATE OF OHIO:

Section 1. That this Council does hereby confirm the approval of the City's Planning Commission of the final site plan submitted by AT&T Mobility, through its agent, for the removal of three (3) existing antennas, the addition of three (3) new antennas and three (3) remote radio heads (RRHs), for the co-location on the existing telecommunications tower, on City-owned property located at 16099 Foltz Parkway (PPN 393-12-002 and 393-10-001).

Section 2. That it is found and determined that all formal actions of this Council concerning and relating to the adoption of this Resolution were adopted in an open meeting of this Council; and that all deliberations of this Council, and any of its committees, that resulted in such formal action were in meetings open to the public in compliance with all legal requirements.

CITY OF STRONGSVILLE, OHIO
RESOLUTION NO. 2017 – 029
Page 2

Section 3. That this Resolution is hereby declared to be an emergency measure immediately necessary for the preservation of the public peace, health, safety and welfare of the City, and for the further reason that it is immediately necessary in order to ensure continuous and proper operation and maintenance of the telecommunications towers and appurtenances located within the City, and to conserve public funds. Therefore, provided this Resolution receives the affirmative vote of two-thirds of all members elected to Council, it shall take effect and be in force immediately upon its passage and approval by the Mayor; otherwise from and after the earliest period allowed by law.

_____ Approved: _____
 President of Council Mayor

Date Passed: _____ Date Approved: _____

	<u>Yea</u>	<u>Nay</u>
Carbone	_____	_____
Daymut	_____	_____
DeMio	_____	_____
Dooner	_____	_____
Schonhut	_____	_____
Short	_____	_____
Southworth	_____	_____

Attest: _____
 Clerk of Council

RES
 ORD. No. 2017-029 Amended: _____
 1st Rdg. _____ Ref: _____
 2nd Rdg. _____ Ref: _____
 3rd Rdg. _____ Ref: _____

 Pub Hrg. _____ Ref: _____
 Adopted: _____ Defeated: _____

MEMORANDUM

TO: Aimee Pientka, Council Clerk
Neal Jamison, Law Director

FROM: Carol Oprea, Administrative Assistant, Boards & Commissions

SUBJECT: Referrals to Council

DATE: February 10, 2017

Please be advised that at its meeting of February 9, 2017, the Strongsville Planning Commission gave Favorable Recommendation the following;

PUZZITIELLO-FRANCESANGELO/ Chris Bender, Agent

Re-subdivision of PPN's 392-13-001, 057 and 058 also known as Sublots 16A and 17A located on Pinnacle Point zoned R1-75.

ORDINANCE 2017-012

An Ordinance Amending the Zoning Map of the City of Strongsville adopted by Section 1250.03 of Title Six, Part Twelve of the Codified Ordinances of Strongsville to change the Zoning Classification of certain real property located at 22044 Royalton Road, in the City of Strongsville, from GI (General Industrial) Classification to R1-125 (One Family 125) Classification (PPN 392-08-002).

AT & T MOBILITY/ Kathy Farina, Agent

Site Plan approval for the addition of 3 new antennas and 3 RRH's and remove 3 existing antennas for the AT & T co-location on an existing telecommunications tower located at 16099 Foltz Parkway, PPN 393-12-002 and 393-10-001 zoned General Industrial.

CITY OF STRONGSVILLE, OHIO

RESOLUTION NO. 2017 – 030

By: Mr. Daymut

A RESOLUTION APPROVING AN AMENDED DEVELOPMENT PLAN FOR THE GREAT ESCAPE PLAZA TO PERMIT CONSTRUCTION OF A DRIVE-THRU RESTAURANT, LOCATED AT 17200 ROYALTON ROAD, IN THE CITY OF STRONGSVILLE; AND DECLARING AN EMERGENCY.

WHEREAS, Great Escape Plaza 15, LLC has proposed an Amendment to the Development Plan for the Great Escape Plaza; and

WHEREAS, Great Escape Plaza 15, LLC, through Dan Neff, its agent, is desirous of amending the Development Plan by providing for the construction of a 2,000 square foot drive-thru restaurant on PPN 396-14-001, located at 17200 Royalton Road, Strongsville, Ohio, which property is zoned Shopping Center; and

WHEREAS, pursuant to Codified Ordinance §1258.17 and §1258.21, Great Escape Plaza 15, LLC, through Dan Neff, its agent, submitted an Amendment to the Final Development Plan to the Planning Commission for its report and recommendation; and

WHEREAS, the Planning Commission approved said proposed Amendment to the Final Development Plan at its meeting of February 23, 2017.

NOW, THEREFORE, BE IT RESOLVED BY THE COUNCIL OF THE CITY OF STRONGSVILLE, COUNTY OF CUYAHOGA, STATE OF OHIO:

Section 1. That this Council hereby approves the Amended Development Plan submitted to the City by Great Escape Plaza 15, LLC, through Dan Neff, its agent, for the Great Escape Plaza, which Amended Development Plan provides for the construction of a 2,000 square foot drive-thru restaurant on PPN 396-14-001, located at 17200 Royalton Road, Strongsville, Ohio, a copy of which is attached hereto as Exhibit A and incorporated herein.

Section 2. That it is found and determined that all formal actions of this Council concerning and relating to the adoption of this Resolution were adopted in an open meeting of this Council; and that all deliberations of this Council, and any of its committees, that resulted in such formal action were in meetings open to the public in compliance with all legal requirements.

CITY OF STRONGSVILLE, OHIO
RESOLUTION NO. 2017 – 030
Page 2

Section 3. That this Resolution is hereby declared to be an emergency measure necessary for the immediate preservation of the public peace, property, health, safety and welfare of the City, and for the further reason that it is immediately necessary to promote development within the City, to preserve jobs, and serve the public. Therefore, provided this Resolution receives the affirmative vote of two-thirds of all members elected to Council, it shall take effect and be in force immediately upon its passage and approval by the Mayor; otherwise from and after the earliest period allowed by law.

 President of Council

Approved: _____
 Mayor

Date Passed: _____ Date Approved: _____

	<u>Yea</u>	<u>Nay</u>
Carbone	_____	_____
Daymut	_____	_____
DeMio	_____	_____
Dooner	_____	_____
Schonhut	_____	_____
Short	_____	_____
Southworth	_____	_____

Attest: _____
 Clerk of Council

RES
 ORD. No. 2017-030 Amended: _____
 1st Rdg. _____ Ref: _____
 2nd Rdg. _____ Ref: _____
 3rd Rdg. _____ Ref: _____

 Pub Hrg. _____ Ref: _____
 Adopted: _____ Defeated: _____

EXHIBIT A

P.P.N. 386-14-017
 F.H.I. INVESTMENTS LTD., II
 VOL. 83-162 AG 931 C.O.D.R.
 K L M N O

FLUPE RELANDER
 BARCEL I
 5,304.7 Acres
 (231,071 Sq. Ft.)

P.P.N. 386-14-007
 F.H.I. INVESTMENTS LTD., II
 VOL. 83-162 AG 931 C.O.D.R.
 K L M N O

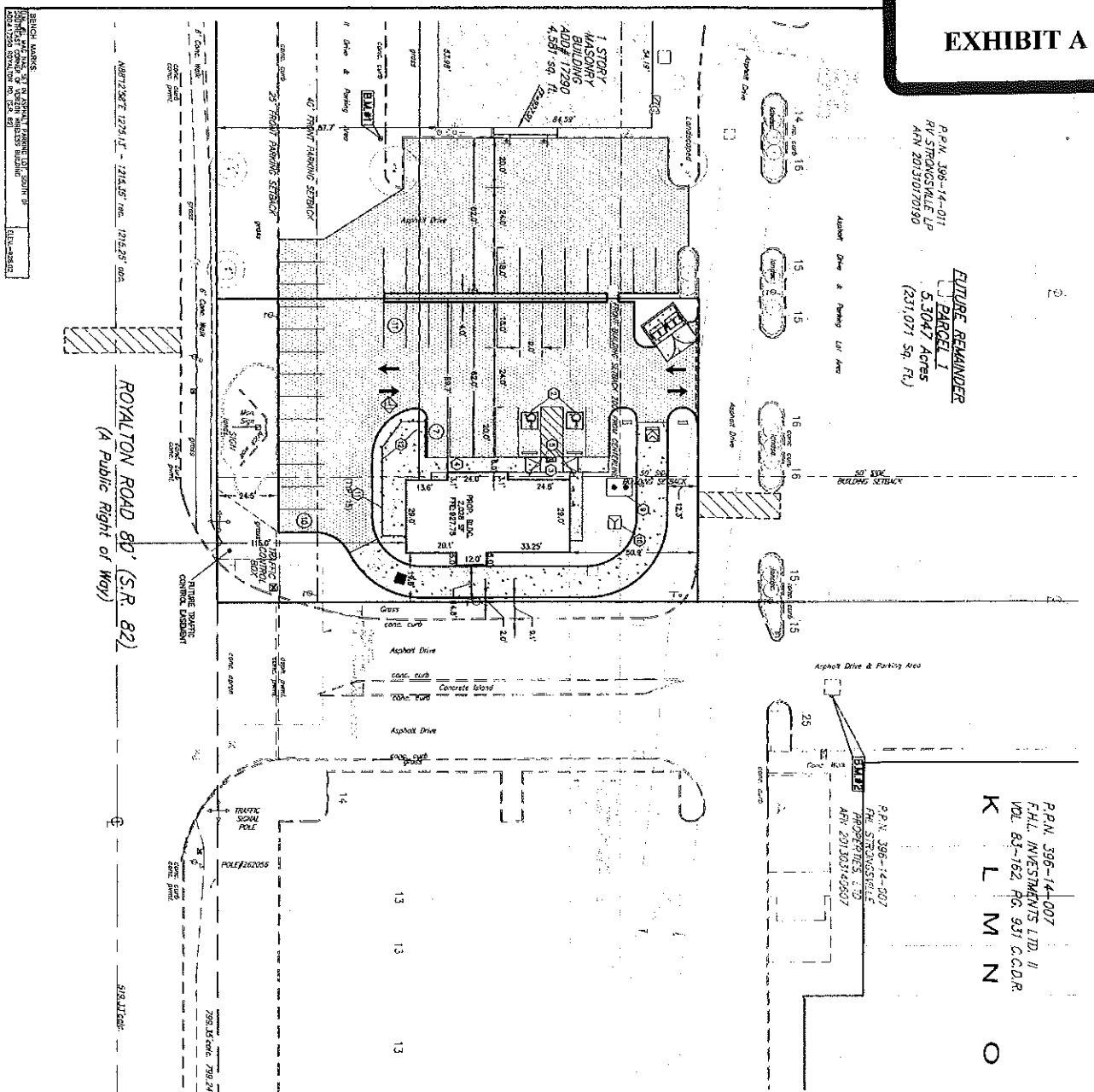

CODE SECTION	SUBJECT	REQUIRED BY ZONING CODE	PROVIDED
1204.12	MAX. HT. OF BLDG.	40 FT.	40 FT.
1204.09	MAX. LOT SIZE	5 ACRES	0.2335 ACRES
1204.08	MAX. LOT COVERAGE (BLDG)	20%	10.3%
1204.11	MIN. FRONT SETBACK (FROM V/L)	20 FT.	11.8 FT.
1204.10	MIN. SIDE SETBACK (FROM V/L)	20 FT.	14.4 FT.
1204.11	MIN. REAR SETBACK - PARKING	20 FT.	2 FT.
1204.11	MIN. REAR SETBACK - BLDG	20 FT.	20.5 FT.
1204.11	MIN. REAR SETBACK - PARKING	20 FT.	12.5 FT.
1204.04	MAX. BLDG. WIDTH (2 WAYS)	24'	24'
1270.04	MINIMUM PARKING STALL SIZE	9 X 20'	28 SPACES
1270.04	MINIMUM # OF SPACES	11 SPACES X 20' (60') 10 FT. OF DRIVE AREA (24' BLDG)	28 SPACES

1. BLDG. FRONT YARDS FOR BUILDINGS AND USES SHALL NOT BE LESS THAN ESTABLISHED IN THE PRECEDING SCHEDULE, AND MINIMUM SIDE YARDS FOR BUILDINGS AND USES SHALL NOT BE LESS THAN ESTABLISHED IN THE PRECEDING SCHEDULE, AND MINIMUM REAR YARDS FOR BUILDINGS AND USES SHALL NOT BE LESS THAN ESTABLISHED IN THE PRECEDING SCHEDULE.

2. THE DISTANCE FROM THE FRONT PARKING SETBACK TO THE FRONT PROPERTY LINE SHALL BE AT LEAST 10 FEET FROM THE CENTER LINE OF THE FRONT PARKING SETBACK OR FRONT YARD FROM THE CENTER PROPERTY LINE WITH A MINIMUM "NET" FRONT SETBACK OF 20 FEET FROM THE CENTER PROPERTY LINE. THE COMBINATION OF THESE SETBACKS SHALL BE AT LEAST 20 FEET FROM THE CENTER PROPERTY LINE.

REQUIREMENT	PROVIDED
REPAIR W/ FOOD SERVICE	CONCRETE SIDEWALK
(47) 208 SF * 4.11% ROAD SERVICE	ASPHALT DRIVEWAY
10 SPACES / 1,000 ROAD SERVICE	ASPHALT DRIVEWAY
(238 SF * 23 SPACES)	ASPHALT DRIVEWAY
1 OFFICE	ASPHALT DRIVEWAY
(4,313 SF * 17 SPACES)	ASPHALT DRIVEWAY
TOTAL REQUIRED = 235 SPACES	249 SPACES PROVIDED
12 SPACES FOR 1,000 SQ. FT. OF	28 SPACES PROVIDED
(248 SF * 24 SPACES)	277 SPACES PROVIDED
REGUL. SITE PARKING REQUIREMENT	
277 SPACES	

- KEY NOTES:**
- VERTICAL CURVED DRIVE
 - MAX. ACCESSIBLE PARKING SPACES
 - MAX. ACCESSIBLE DRIVE
 - CONCRETE SIDEWALK
 - ACCESSIBLE PARKING SPACES
 - ASPHALT DRIVEWAY
 - MINIMUM FRONT DRIVEWAY WIDTH
 - MINIMUM SIDE DRIVEWAY WIDTH
 - MINIMUM REAR DRIVEWAY WIDTH
 - MINIMUM DRIVEWAY WIDTH
 - MINIMUM DRIVEWAY WIDTH
 - MINIMUM DRIVEWAY WIDTH
 - MINIMUM DRIVEWAY WIDTH
 - MINIMUM DRIVEWAY WIDTH
 - MINIMUM DRIVEWAY WIDTH

REVISION	DATE	BY	FOR
REVISED SITE PLAN	02/07/17		
REVISED SITE PLAN	07/23/17		
PLANNING COMMISSION	07/27/17		

MEMORANDUM

TO: Aimee Pientka, Council Clerk
Neal Jamison, Law Director

FROM: Carol Oprea, Administrative Assistant, Boards & Commissions

SUBJECT: Referrals to Council

DATE: February 24, 2017

Please be advised that at its meeting of February 23, 2017, the Strongsville Planning Commission gave Favorable Recommendation the following;

OUTLOT AT THE GREAT ESCAPE PLAZA/ Dan Neff, Agent

Amendment to Final Development Plan and Site Plan approval of a 2,000 SF Drive thru restaurant for the Starbucks drive-thru located at 17200 Royalton Road, PPN 396-14-001 zoned Shopping Center.

CITY OF STRONGSVILLE, OHIO

ORDINANCE NO. 2017 – 031

By: Mayor Perciak and Mr. Southworth

AN ORDINANCE AUTHORIZING THE MAYOR TO ENTER INTO A CONTRACT FOR THE COMPLETE RENOVATION OF FOUR LOCKER ROOM/RESTROOM FACILITIES AT THE CITY OF STRONGSVILLE WALTER F. EHRSFELT RECREATION & SENIOR CENTER, AND DECLARING AN EMERGENCY.

WHEREAS, the City has advertised and received bids for the complete renovation of four (4) locker room/restroom facilities at the Walter F. Ehrnfelt Recreation & Senior Center; and

WHEREAS, Council is desirous of proceeding to award and enter into a contract for such project.

NOW, THEREFORE, BE IT ORDAINED BY THE COUNCIL OF THE CITY OF STRONGSVILLE, COUNTY OF CUYAHOGA AND STATE OF OHIO:

Section 1. That this Council hereby finds and determines that the bid submitted by **ALABASI CONSTRUCTION, INC.**, for the complete renovation of four (4) locker room/restroom facilities at the Walter F. Ehrnfelt Recreation & Senior Center, meets the specifications on file in the office of the Building Commissioner; is in compliance with the applicable requirements for bids and contracts established by the laws of the City and the State; and is the lowest and best bid for the proposed contract. All other bids for this contract are hereby rejected.

Section 2. That the Mayor be and is hereby authorized and directed to enter into a contract with the aforesaid lowest and best bidder in the amount of \$662,750.00 for the complete renovation of four (4) locker room/restroom facilities at the Walter F. Ehrnfelt Recreation & Senior Center, and in a form approved by the Law Director.

Section 3. That the funds for the purposes of this Ordinance have been appropriated and shall be paid from the Recreation Capital Improvement Fund.

Section 4. That it is found and determined that all formal actions of this Council concerning and relating to the adoption of this Ordinance were adopted in an open meeting of this Council; and that all deliberations of this Council, and any of its committees, that resulted in such formal action were in meetings open to the public in compliance with all legal requirements.

Section 5. That this Ordinance is hereby declared to be an emergency measure immediately necessary for the preservation of the public peace, health, safety and welfare of the City, and for the further reason that it is immediately necessary to authorize execution of said contract in order to make necessary improvements to the Recreation Center locker room and restroom facilities for the safety and comfort of its patrons, guest and employees, and to conserve public funds. Therefore, provided this Ordinance receives the affirmative vote of two-thirds of all members elected to Council, it shall take effect and be in force immediately upon its passage and approval by the Mayor; otherwise from and after the earliest period allowed by law.

 President of Council

Approved: _____
 Mayor

Date Passed: _____

Date Approved: _____

	<u>Yea</u>	<u>Nay</u>
Carbone	_____	_____
Daymut	_____	_____
DeMio	_____	_____
Dooner	_____	_____
Schonhut	_____	_____
Short	_____	_____
Southworth	_____	_____

Attest: _____
 Clerk of Council

ORD. No. 2017-031 Amended: _____
 1st Rdg. _____ Ref: _____
 2nd Rdg. _____ Ref: _____
 3rd Rdg. _____ Ref: _____

 Pub Hrg. _____ Ref: _____
 Adopted: _____ Defeated: _____

CITY OF STRONGSVILLE, OHIO

ORDINANCE NO. 2017 – 032

By: Mr. Carbone

AN ORDINANCE AUTHORIZING THE DISPOSAL OF A DEPARTMENT OF PUBLIC SERVICE VEHICLE AND CERTAIN EQUIPMENT NO LONGER NEEDED FOR ANY MUNICIPAL PURPOSE, AND DECLARING AN EMERGENCY.

BE IT ORDAINED BY THE COUNCIL OF THE CITY OF STRONGSVILLE, COUNTY OF CUYAHOGA AND STATE OF OHIO:

Section 1. That this Council finds that the City of Strongsville has a vehicle and certain equipment, which are surplus, have no monetary value and are no longer needed for any municipal purpose; and further finds that it would be in the best interest of the City to dispose of such vehicle and equipment. Said vehicle and equipment are more fully set forth in Exhibit "A," attached hereto and incorporated herein by reference.

Section 2. That, pursuant to Article IV, §3(e) of the City Charter, the Director of Finance be and is hereby authorized to dispose of such obsolete vehicle and equipment identified in Exhibit "A" through Reed's Salvage Corp., and to perform all acts required in furtherance thereof.

Section 3. That it is found and determined that all formal actions of this Council concerning and relating to the adoption of this Ordinance were adopted in an open meeting of this Council; and that all deliberations of this Council, and any of its committees, that resulted in such formal action were in meetings open to the public in compliance with all legal requirements.

Section 4. That this Ordinance is hereby declared to be an emergency measure necessary for the immediate preservation of the public peace, property, health, safety and welfare of the City, and for the further reason that the immediate disposal of such obsolete and surplus vehicle and equipment is necessary in order to provide needed storage space for the Department of Public Service, and to conserve public funds. Therefore, provided this Ordinance receives the affirmative vote of two-thirds of all members elected to Council, it shall take effect and be in force immediately upon its passage and approval by the Mayor; otherwise from and after the earliest period allowed by law.

CITY OF STRONGSVILLE, OHIO
ORDINANCE NO. 2017 - 032
Page 2

President of Council

Approved: _____
Mayor

Date Passed: _____

Date Approved: _____

	<u>Yea</u>	<u>Nay</u>
Carbone	_____	_____
Daymut	_____	_____
DeMio	_____	_____
Dooner	_____	_____
Schonhut	_____	_____
Short	_____	_____
Southworth	_____	_____

Attest: _____
Clerk of Council

ORD. No. 2017-032 Amended: _____

1st Rdg. _____ Ref: _____

2nd Rdg. _____ Ref: _____

3rd Rdg. _____ Ref: _____

Pub Hrg. _____ Ref: _____

Adopted: _____ Defeated: _____

Equipment going to scrap

Model 240 Tenant Floor Sweeper VIN# 2405723 ID# 240

Model 385 Tenant Floor Sweeper VIN# 3856922 ID# 385

1997 Dodge Dakota VIN# 1B7GG23Y2VS207055 ID# 297

EXHIBIT A

CITY OF STRONGSVILLE, OHIO

RESOLUTION NO. 2017 – 033

By: Mayor Perciak and Mr. Carbone

A RESOLUTION AUTHORIZING THE MAYOR TO ADVERTISE FOR BIDS FOR SWEEPING OF STREETS FOR 2017 AND 2018, WITHIN THE CITY OF STRONGSVILLE.

BE IT RESOLVED BY THE COUNCIL OF THE CITY OF STRONGSVILLE, COUNTY OF CUYAHOGA, AND STATE OF OHIO:

Section 1. That the Mayor be and is hereby authorized to advertise for bids for sweeping of streets within the City of Strongsville during the period of 2017-2018, in accordance with specifications on file in the office of the Director of Public Service, which are in all respects hereby approved.

Section 2. That the funds for the purposes of this Resolution have been appropriated and shall be paid from the Street Construction, Maintenance and Repair Fund.

Section 3. That it is found and determined that all formal actions of this Council concerning and relating to the adoption of this Resolution were adopted in an open meeting of this Council; and that all deliberations of the Council and any of its committees that resulted in such formal action were in meetings open to the public in compliance with all legal requirements.

Section 4. That this Resolution shall take effect and be in force immediately upon its passage and approval by the Mayor.

President of Council
Approved: _____
Mayor

Date Passed: _____ Date Approved: _____

	<u>Yea</u>	<u>Nay</u>
Carbone	_____	_____
Daymut	_____	_____
DeMio	_____	_____
Dooner	_____	_____
Schonhut	_____	_____
Short	_____	_____
Southworth	_____	_____

Attest: _____
Clerk of Council

RES
ORD. No. 2017-033 Amended: _____
1st Rdg. _____ Ref: _____
2nd Rdg. _____ Ref: _____
3rd Rdg. _____ Ref: _____

Pub Hrg. _____ Ref: _____
Adopted: _____ Defeated: _____

CITY OF STRONGSVILLE, OHIO

RESOLUTION NO. 2017 – 034

By: Mayor Perciak and Mr. Carbone

A RESOLUTION AUTHORIZING THE MAYOR TO ADVERTISE FOR BIDS FOR MATERIALS AND SERVICES IN CONNECTION WITH THE PAINT STRIPING OF CERTAIN STREETS AND HIGHWAYS FOR 2017 AND 2018, WITHIN THE CITY OF STRONGSVILLE.

BE IT RESOLVED BY THE COUNCIL OF THE CITY OF STRONGSVILLE, COUNTY OF CUYAHOGA, AND STATE OF OHIO:

Section 1. That the Mayor be and is hereby authorized to advertise for bids for materials and services in connection with the paint striping of certain streets and highways within the City of Strongsville during the period of 2017-2018, in accordance with specifications on file in the office of the Director of Public Service, which are in all respects hereby approved.

Section 2. That the funds for the purposes of this Resolution have been appropriated and shall be paid from the Street Construction, Maintenance and Repair Fund.

Section 3. That it is found and determined that all formal actions of this Council concerning and relating to the adoption of this Resolution were adopted in an open meeting of this Council; and that all deliberations of the Council and any of its committees that resulted in such formal action were in meetings open to the public in compliance with all legal requirements.

Section 4. That this Resolution shall take effect and be in force immediately upon its passage and approval by the Mayor.

President of Council
Approved: _____
Mayor

Date Passed: _____ Date Approved: _____

	<u>Yea</u>	<u>Nay</u>
Carbone	_____	_____
Daymut	_____	_____
DeMio	_____	_____
Dooner	_____	_____
Schonhut	_____	_____
Short	_____	_____
Southworth	_____	_____

Attest: _____
Clerk of Council

RES
 ORD. No. 2017-034 Amended: _____
 1st Rdg. _____ Ref: _____
 2nd Rdg. _____ Ref: _____
 3rd Rdg. _____ Ref: _____

Pub Hrg. _____ Ref: _____
Adopted: _____ Defeated: _____

CITY OF STRONGSVILLE, OHIO

RESOLUTION NO. 2017 – 035

By: Mayor Perciak and Mr. Carbone

A RESOLUTION AUTHORIZING THE MAYOR TO ADVERTISE FOR BIDS FOR THE PURCHASE OF VEHICLE AND EQUIPMENT TIRES AND RELATED TIRE SERVICES FOR 2017 AND 2018, TO BE USED BY THE SERVICE DEPARTMENT OF THE CITY OF STRONGSVILLE.

BE IT RESOLVED BY THE COUNCIL OF THE CITY OF STRONGSVILLE, COUNTY OF CUYAHOGA, AND STATE OF OHIO:

Section 1. That the Mayor be and is hereby authorized to advertise for bids for the purchase of vehicle and equipment tires and related tire services for 2017 and 2018, to be used by the Service Department of the City of Strongsville, in accordance with specifications on file in the office of the Director of Public Service, which are in all respects hereby approved.

Section 2. That the funds for the purposes of this Resolution have been appropriated and shall be paid from the General Fund; Street Construction, Maintenance and Repair Fund; Emergency Vehicle Fund; Fire Levy Fund; Multi-Purpose Complex Fund; and Sanitary Sewer Fund.

Section 3. That it is found and determined that all formal actions of this Council concerning and relating to the adoption of this Resolution were adopted in an open meeting of this Council; and that all deliberations of the Council and any of its committees that resulted in such formal action were in meetings open to the public in compliance with all legal requirements.

Section 4. That this Resolution shall take effect and be in force immediately upon its passage and approval by the Mayor.

President of Council

Approved: _____
Mayor

Date Passed: _____

Date Approved: _____

	<u>Yea</u>	<u>Nay</u>
Carbone	_____	_____
Daymut	_____	_____
DeMio	_____	_____
Dooner	_____	_____
Schonhut	_____	_____
Short	_____	_____
Southworth	_____	_____

Attest: _____
Clerk of Council

RES
 ORD. No. _____ Amended: _____
 1st Rdg. _____ Ref: _____
 2nd Rdg. _____ Ref: _____
 3rd Rdg. _____ Ref: _____

 Pub Hrg. _____ Ref: _____
 Adopted: _____ Defeated: _____

CITY OF STRONGSVILLE, OHIO

RESOLUTION NO. 2017 – 036

By: Mayor Perciak and Mr. Carbone

A RESOLUTION AUTHORIZING THE MAYOR TO ADVERTISE FOR BIDS FOR THE PURCHASE OF ASPHALT MATERIALS FOR USE DURING 2017 AND 2018 BY THE SERVICE DEPARTMENT OF THE CITY OF STRONGSVILLE.

BE IT RESOLVED BY THE COUNCIL OF THE CITY OF STRONGSVILLE, COUNTY OF CUYAHOGA, AND STATE OF OHIO:

Section 1. That the Mayor be and is hereby authorized to advertise for bids for the purchase of asphalt materials for use during 2017 and 2018 by the Service Department of the City of Strongsville, in accordance with specifications on file in the office of the Director of Public Service, which are in all respects hereby approved.

Section 2. That the funds for the purposes of this Resolution have been appropriated and shall be paid from the Street Construction, Maintenance and Repair Fund.

Section 3. That it is found and determined that all formal actions of this Council concerning and relating to the adoption of this Resolution were adopted in an open meeting of this Council; and that all deliberations of the Council and any of its committees that resulted in such formal action were in meetings open to the public in compliance with all legal requirements.

Section 4. That this Resolution shall take effect and be in force immediately upon its passage and approval by the Mayor.

President of Council
Approved: _____
Mayor

Date Passed: _____ Date Approved: _____

	<u>Yea</u>	<u>Nay</u>
Carbone	_____	_____
Daymut	_____	_____
DeMio	_____	_____
Dooner	_____	_____
Schonhut	_____	_____
Short	_____	_____
Southworth	_____	_____

Attest: _____
Clerk of Council

RES
ORD. No. 2017-036 Amended: _____
1st Rdg. _____ Ref: _____
2nd Rdg. _____ Ref: _____
3rd Rdg. _____ Ref: _____

Pub Hrg. _____ Ref: _____
Adopted: _____ Defeated: _____

CITY OF STRONGSVILLE, OHIO

RESOLUTION NO. 2017 – 037

By: Mayor Perciak and Mr. Carbone

A RESOLUTION AUTHORIZING THE MAYOR TO ADVERTISE FOR BIDS FOR THE PURCHASE OF GENERAL PAVEMENT SERVICES FOR 2017 FOR USE BY THE SERVICE DEPARTMENT OF THE CITY OF STRONGSVILLE.

BE IT RESOLVED BY THE COUNCIL OF THE CITY OF STRONGSVILLE, COUNTY OF CUYAHOGA, AND STATE OF OHIO:

Section 1. That the Mayor be and is hereby authorized to advertise for bids for the purchase of general pavement services for use during 2017 by the Service Department of the City of Strongsville, in accordance with specifications on file in the office of the Director of Public Service, which are in all respects hereby approved.

Section 2. That the funds for the purposes of this Resolution have been appropriated and shall be paid from the Street Construction, Maintenance and Repair Fund.

Section 3. That it is found and determined that all formal actions of this Council concerning and relating to the adoption of this Resolution were adopted in an open meeting of this Council; and that all deliberations of the Council and any of its committees that resulted in such formal action were in meetings open to the public in compliance with all legal requirements.

Section 4. That this Resolution shall take effect and be in force immediately upon its passage and approval by the Mayor.

President of Council

Approved: _____
Mayor

Date Passed: _____

Date Approved: _____

	<u>Yea</u>	<u>Nay</u>
Carbone	_____	_____
Daymut	_____	_____
DeMio	_____	_____
Dooner	_____	_____
Schonhut	_____	_____
Short	_____	_____
Southworth	_____	_____

Attest: _____
Clerk of Council

RES
 ORD. No. _____ Amended: _____
 1st Rdg. _____ Ref: _____
 2nd Rdg. _____ Ref: _____
 3rd Rdg. _____ Ref: _____

Pub Hrg. _____ Ref: _____
Adopted: _____ Defeated: _____

CITY OF STRONGSVILLE, OHIO

ORDINANCE NO. 2017 – 038

By: Mr. DeMio

AN ORDINANCE AUTHORIZING THE MAYOR TO ENTER INTO A CONTRACT FOR THE PURCHASE OF A NEW 2017 FORD EXPEDITION SSV EXTENDED LENGTH WITH MARKED VEHICLE LIGHTING PACKAGE, FOR USE BY THE CITY'S FIRE DEPARTMENT, WITHOUT PUBLIC BIDDING, AND DECLARING AN EMERGENCY.

WHEREAS, the Fire Department is in immediate need of a new truck; and

WHEREAS, Ohio Revised Code (ORC) Section 5513.01(B) provides the opportunity for counties, townships and municipal corporations to participate in contracts of the Ohio Department of Administrative Services for the purchase of machinery, materials, supplies or other articles; and

WHEREAS, ORC Section 125.04(C) provides that a political subdivision can purchase supplies or services from another party upon equivalent terms, conditions and specifications but at a lower price than it can through those contracts under ORC Section 5513.01(B); and

WHEREAS, local vendors are able to provide emergency vehicles and appurtenances to the City, along with the proper equipment and installation of accessories on an expedited basis, and at a most advantageous price which is below the comparable State Term contract price; and

WHEREAS, the Fire Department, therefore, recommends and seeks authority to proceed on an expedited basis and without public bidding for such purchases.

NOW, THEREFORE, BE IT ORDAINED BY THE COUNCIL OF THE CITY OF STRONGSVILLE, COUNTY OF CUYAHOGA AND STATE OF OHIO BY UNANIMOUS AFFIRMATIVE VOTE:

Section 1. That this Council finds that the City's Fire Department is in need of a new 2017 Ford Expedition SSV Extended Length, 4x4, with marked vehicle lighting package with appurtenances and Extendo Bed Command Center, which can be obtained most advantageously through Statewide Ford Lincoln and Statewide Emergency Products.

Section 2. That this Council finds and determines, as set out in Article V, §5 of the Charter, that there is an immediate and present emergency in the operation of the Fire Department of the City of Strongsville, in that it is immediately necessary to enter into a contract, without public bidding, to purchase the new 2017 Ford Expedition SSV Extended Length, 4x4, with marked vehicle lighting package with appurtenances and Extendo Bed Command Center.

CITY OF STRONGSVILLE, OHIO

ORDINANCE NO. 2017 - 038

Page 2

Section 3. That, for the reasons aforesaid, the Mayor be and is hereby authorized to enter into agreements, without public bidding, with **STATEWIDE FORD LINCOLN** for the purchase of a new 2017 Ford Expedition SSV Extended Length, 4x4, and with **STATEWIDE EMERGENCY PRODUCTS**, for a marked vehicle lighting package with appurtenances and Extendo Bed Command Center, all in the total amount of \$50,709.00, as more fully set forth on Exhibit A, attached hereto and incorporated herein by reference.

Section 4. That the funds for the purposes of said contract have been appropriated and shall be paid from the Emergency Vehicle Fund.

Section 5. That it is found and determined that all formal actions of this Council concerning and relating to the adoption of this Ordinance were adopted in an open meeting of this Council; and that all deliberations of this Council, and any of its committees, that resulted in such formal action were in meetings open to the public in compliance with all legal requirements.

Section 6. That this Ordinance is hereby declared to be an emergency measure necessary for the immediate preservation of the public peace, property, health, safety and welfare of the City, and for the further reason that it is immediately necessary to enter into said contract in order to maintain continuity in the operation of the City of Strongsville Fire Department, to provide for the safety and welfare of the public, and to conserve public funds. Therefore, provided this Ordinance receives the unanimous vote of all members elected to Council, it shall take effect and be in force immediately upon its passage and approval by the Mayor.

President of Council
Approved: _____
Mayor

Date Passed: _____ Date Approved: _____

	<u>Yea</u>	<u>Nay</u>
Carbone	_____	_____
Daymut	_____	_____
DeMio	_____	_____
Dooner	_____	_____
Schonhut	_____	_____
Short	_____	_____
Southworth	_____	_____

Attest: _____
Clerk of Council

ORD. No. 2017-038 Amended: _____
 1st Rdg. _____ Ref: _____
 2nd Rdg. _____ Ref: _____
 3rd Rdg. _____ Ref: _____

 Pub Hrg. _____ Ref: _____
 Adopted: _____ Defeated: _____

Statewide Ford Lincoln
 1108 W. Main St.
 Van Wert, Ohio 45891

Reference Number	SR02730
Date	Vehicle Status
2/14/2017	Other Quote

2017 Expedition EL

Customer Information

Purchaser Name	Strongsville Fire Dept.
Contact Name	Chief Jack Draves
Mailing Address	17000 Prospect Rd.
City, State & Zip	Strongsville, OH 44149

Contact Information

Email	jack.draves@strongsville.org
Phone	440-580-3217
Fax	
Alt. Contact	Asst Chief AJ Aljabi

Notes Section: The last day to order the 2017 Ford Expedition is 3/2/17. The price will only be valid until that cutoff date as well. This Quote does include the Extendo Bed and the installation of an Extendo Bed as well as the installation of additional radio chassis for Extendo Bed with additional power for flashlight and/or computer plug in.

Shipping

<input type="checkbox"/> Ship to Shop	<input checked="" type="checkbox"/> Build	<input type="checkbox"/> Deliver
<input type="checkbox"/> Pull From Inventory		
<input type="checkbox"/> Manufacturer Ship Direct		

Supporting Information

Sales Rep Name	Steve Rick
Customer PO #	
Delivery Address	
City, State & Zip	

<u>QTY</u>	<u>Manufacturer</u>	<u>Part Number</u>	<u>Part Description</u>	<u>Unit Price</u>	<u>Extended Price</u>	<u>Cost of Options</u>
1	Ford	U1G	2017 Ford Expedition SSV Extended Length, 4x4	\$ 34,740.00	\$ 34,740.00	
1	Ford	41K	Skid Plates	\$ 96.00	\$ 96.00	
1	Ford	536	Trailer Tow	\$ 560.00	\$ 560.00	
1	Ford	DELIVERY	Delivery charge (\$0.40 x 362 miles, roundtrip)	\$ 145.00	\$ 145.00	
1	Statewide Emergency Products	MCL	Marked vehicle package, installed	\$ 5,250.00	\$ 5,250.00	
1	Whelen	GS8	Legacy Solo Light Bar All Red Flashing Alley & TD	\$ -	\$ -	
1	Whelen	MKEZ60	Light Bar Hook Kit	\$ -	\$ -	
1	Whelen	295SLSA6	295 Siren & Switch Control	\$ -	\$ -	
1	Whelen	SA315P	100 Watt Speaker	\$ -	\$ -	
1	Whelen	SAK23	Speaker Bracket	\$ -	\$ -	
2	Sound Off Signal	ELUC2S010R	LED insert, Red (tail light install)	\$ -	\$ -	
2	Sound Off Signal	ELUC2S010W	LED insert, White (head light install)	\$ -	\$ -	
2	Sound Off Signal	ENFFTSSMS6E	Dual Red/Clear LED for Grill	\$ -	\$ -	
2	Sound Off Signal		Bracket for grill light install	\$ -	\$ -	
1	ShoMe	14.0553	3 DC outlet adapter box	\$ -	\$ -	
1	Whelen	D6RRRRRR	Dominator 6-head mini light bar, All Red	\$ 399.00	\$ 399.00	
1	Whelen	DBKT4	Mounting kit for Dominator	\$ -	\$ -	

Steve Rick
 steverick@statewideford.com

P: (419) 771-2850

EXHIBIT A

